

Installation and Home Owner's Guide

In Wall Tank

4178A , 4179A

THE BOLD LOOK
OF **KOHLER**®

Thank You For Choosing Kohler Company

We appreciate your commitment to Kohler quality. Please take a few minutes to review this manual before you start installation. If you encounter any installation or performance problems, please don't hesitate to contact us. Our phone numbers are listed on the back cover. Thanks again for choosing Kohler Company.

Tools and Materials



10" Adjustable Wrench



Supply Shut-Off Valve

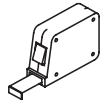

Tape Measure

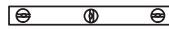

Level



Sponge

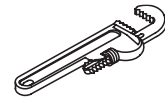

Pipe Wrench

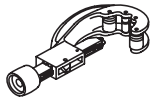

Tubing Cutter



Safety Glasses



Drill and assorted bits

Plus:

- Connector
- Metal File
- 1/2" Nut Driver/Socket
- Hacksaw
- Screwdriver
- M8 Coach/ TEK Screws x4

Before You Begin

Read the installation guide carefully and install the product accordingly. The product information contained in this publication is correct at the time of printing. Kohler Co. reserves the right to implement changes or product characteristics, packaging and availability at any time without further notice. Do not use corrosive cleaners or solvents in or on the tank. This may damage the tank. Do not use any spare parts which are not supplied by Kohler. Kohler will not be responsible for any damage due to the installation of non approved spare parts.

Warning

This product is designed for a water supply pressure range of 20 psi (137kPa) minimum to 80psi (550 kPa) maximum.

Any installations where the supply pressure is outside of these limits will not be covered by warranty.

Ordering Information

Combination SKU's	
SKU	Description
4178A-NA	In wall tank 3/6L (88mm)
4179A-NA	In wall tank 3/4.5L (88mm)

Features

- Anti back flow device.
- Adjustable water inlet level.
- Adjustable flush volume.
- Dual flush.
- Adjustable toilet fixing height.

Design And Installation Concept of in wall Tank

- Designed for easy installation.
- Flexible installation for stud or brick wall construction.

Advantages Of In-wall Tank

- Corrosion resistant and leak proof design.
- Dual 3/4.5 or 3/6 litres flush.
- Easy installation for stud.
- Easy maintenance.
- Space saving.

Rough-in

In Wall Tank Dimensions.

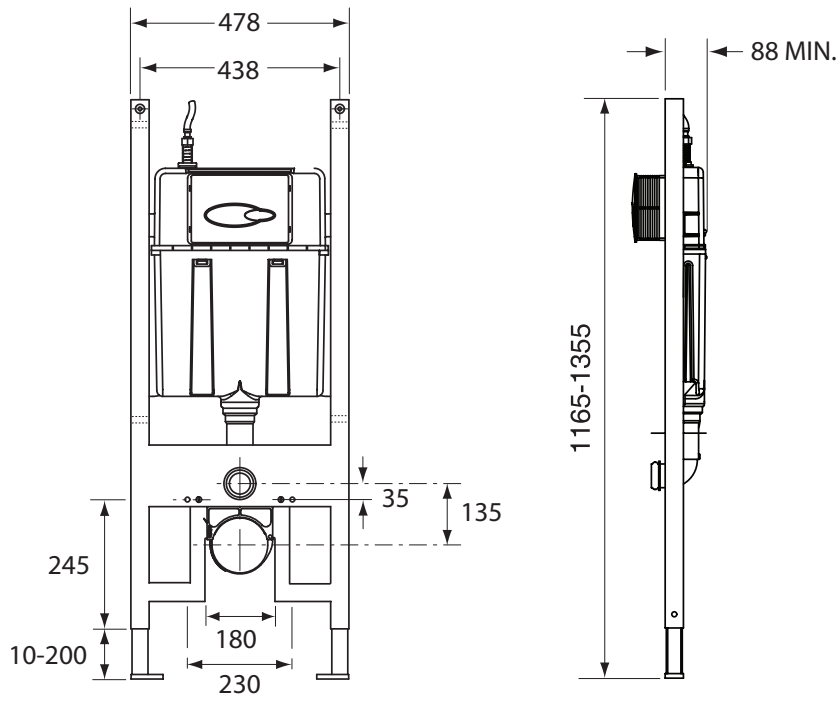

Unit: mm

Installation dimensions stud wall installation

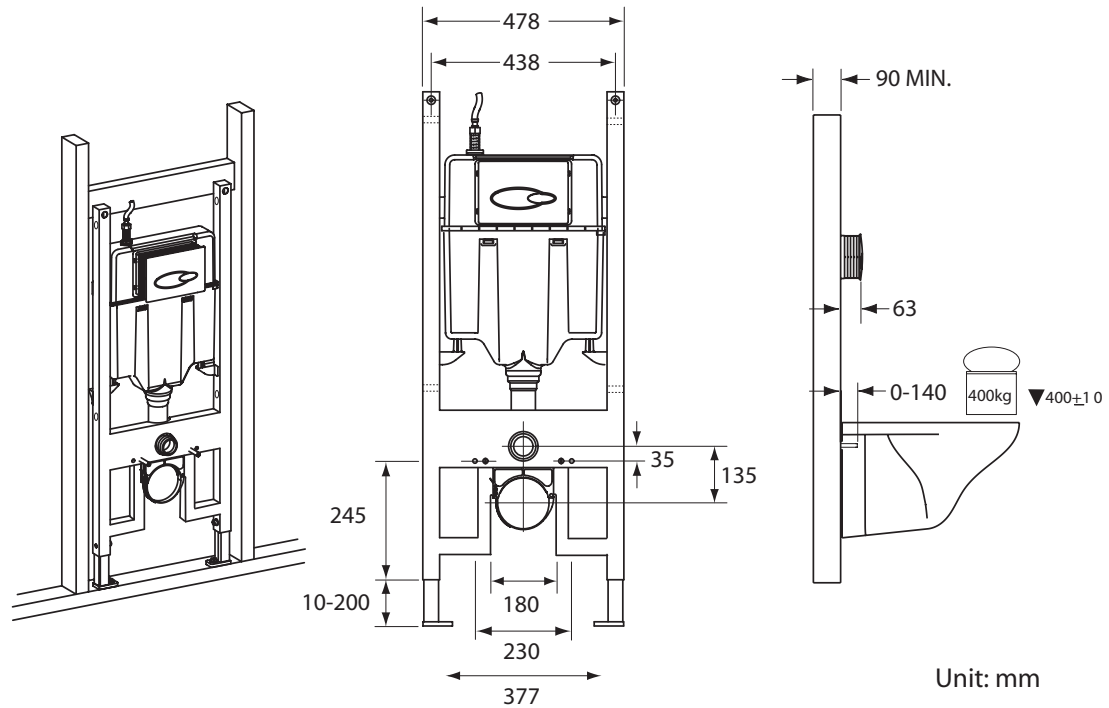

Unit: mm

Installation Procedures for an In-wall Tank in a Stud Wall

1. Minimum cavity (stud pocket) dimensions for installation of the in-wall tank, 553mm wide, 90mm deep.

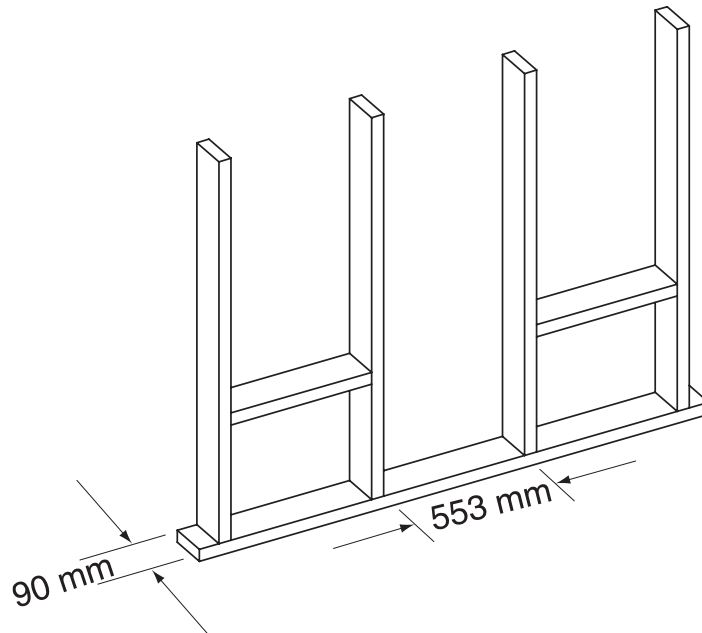

2. Loosen the nut securing the adjustable bracket and extend to their full height. Tighten the nut. Fit the toilet fixing bolts in the required position to suit the toilet fixing holes. (180mm or 230mm) Refer to toilet installation instructions. If no fixing kit is supplied with the toilet, use the fixing kit supplied with the tank. Use lubricant as required and ensure enough of the screw is exposed to mount and secure the toilet.

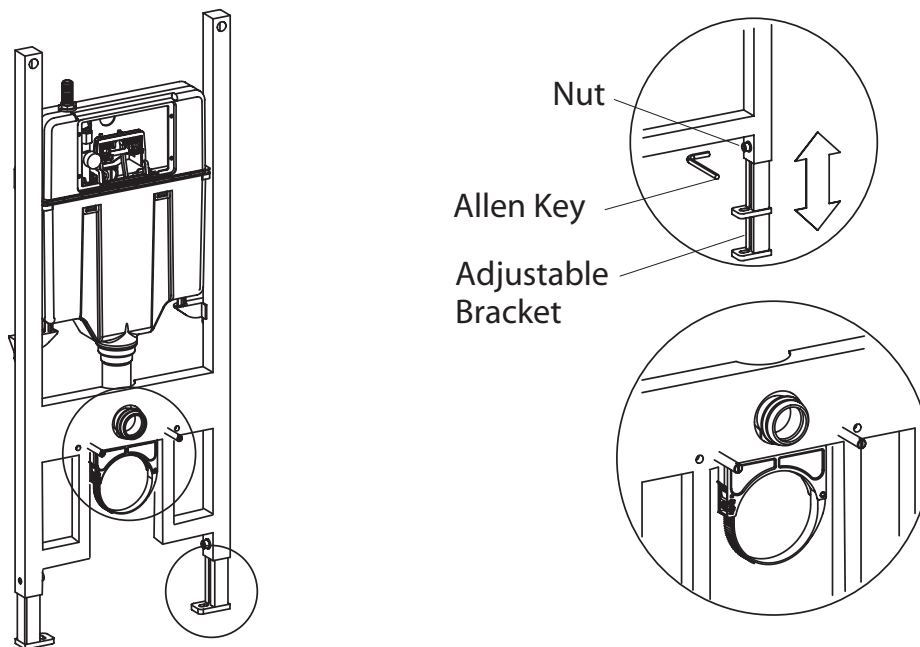

3. Place the frame into the cavity (stud pocket), ensuring the front face of the frame is flush with the front of stud. Fix the adjustable brackets to the base plate with coach tek screws M8 (not supplied).

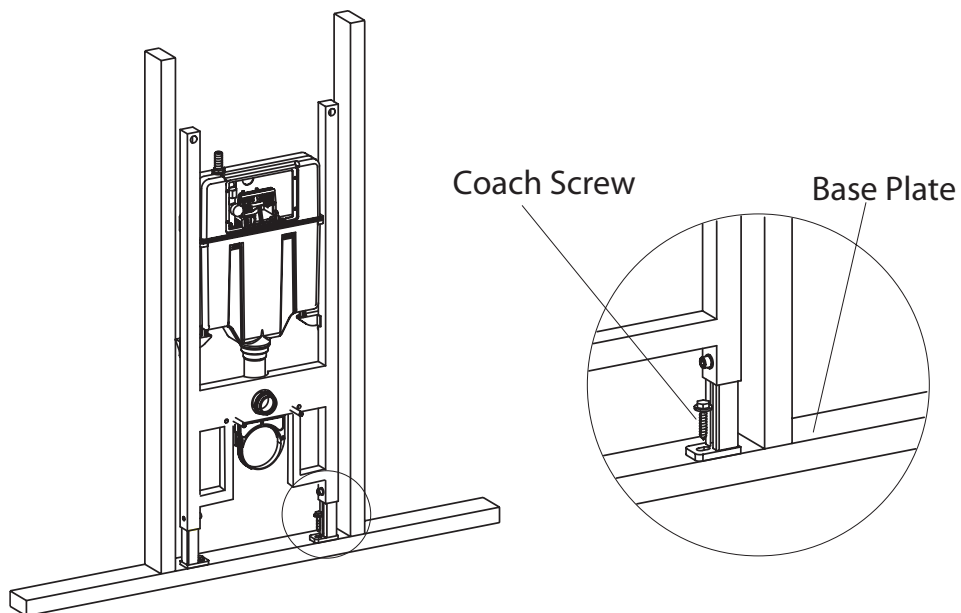

4. Loosen the nut securing the adjustable bracket and adjust the height of the frame to the dimensions stated in the toilet manufactures instructions. The rim of the toilet should be approximately 400mm above the finished floor level.

NOTE: Ensure the frame is supported and not allowed to fall over.

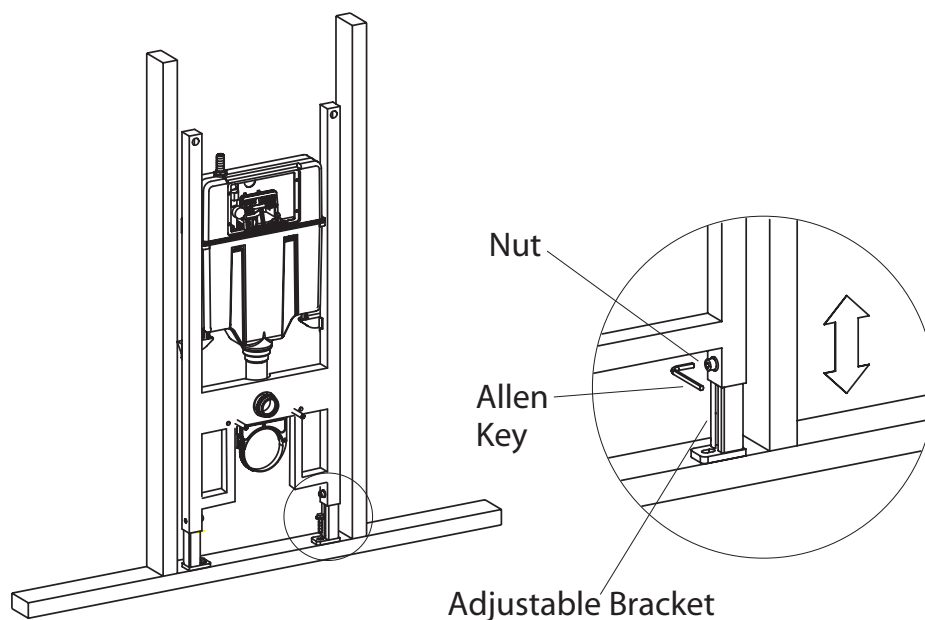

5. Place the nog (not supplied) behind the frame, ensuring the bottom face of the no is below the fixing hole to provide enough area for a secure fixing. Ensure the nog is level.

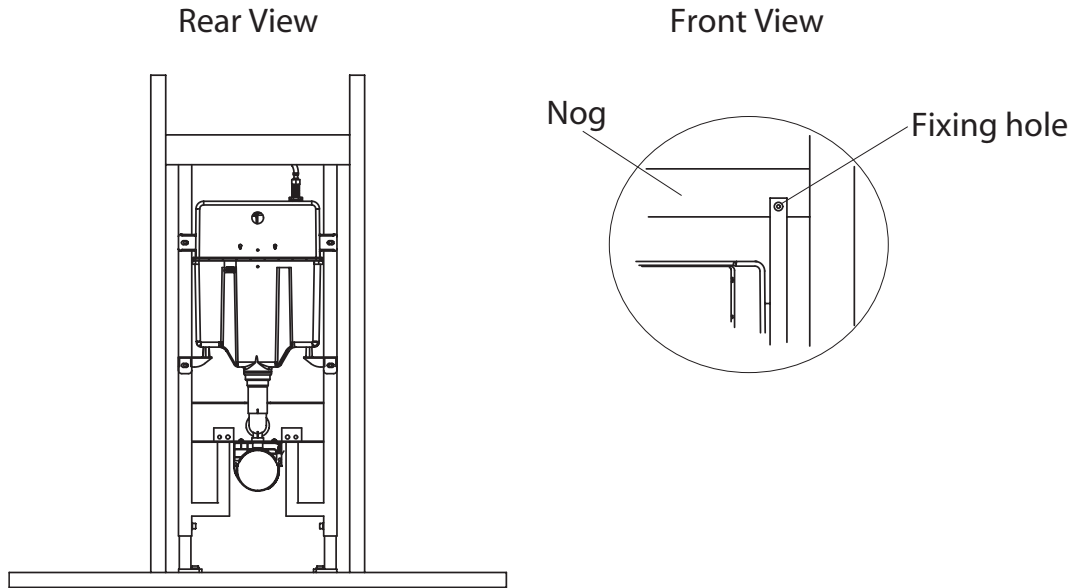

6. Mark the position on both vertical studs. Remove the nog.

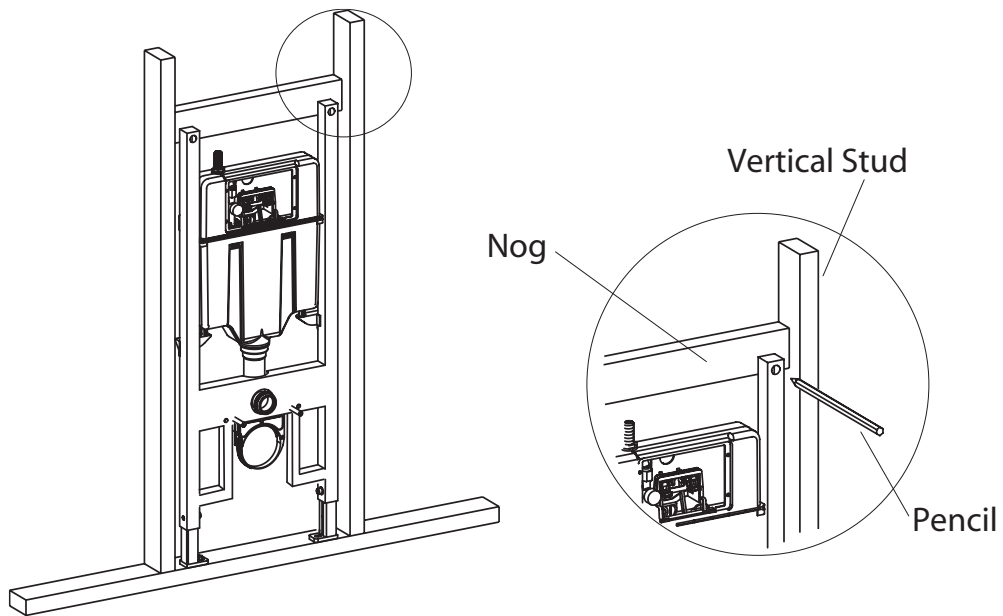

7. Fix the nog to the studs.

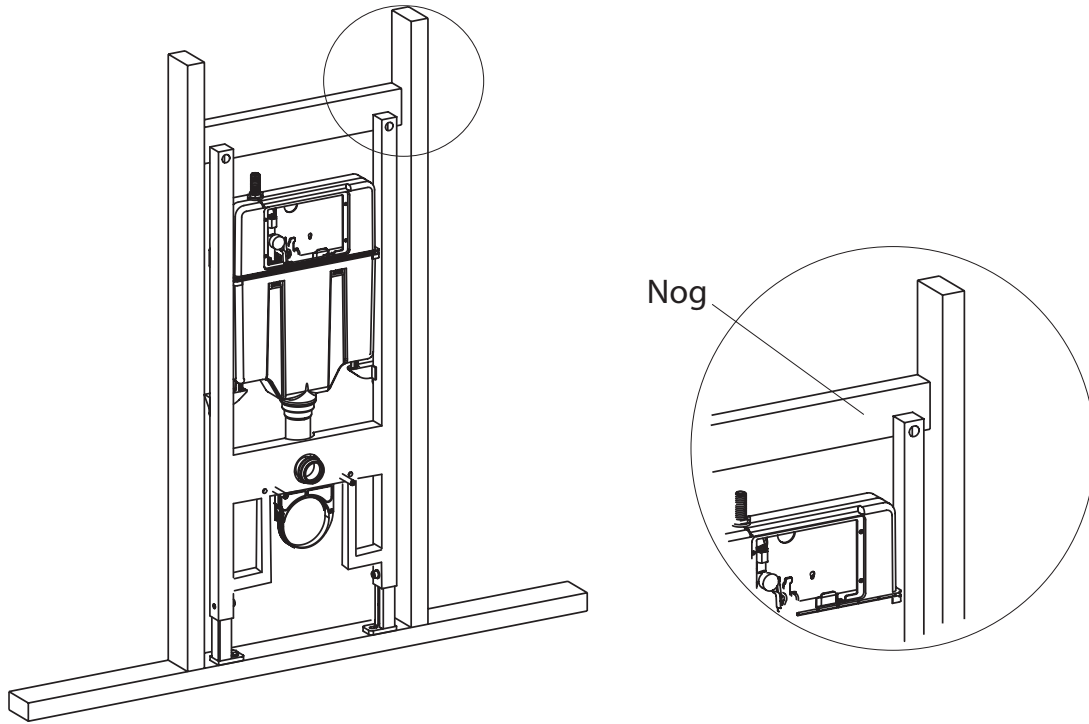

8. Attach the frame to the nog and also the studs at all 6 fixing hole points. Use minimum M8 coach/tek screws (not supplied).

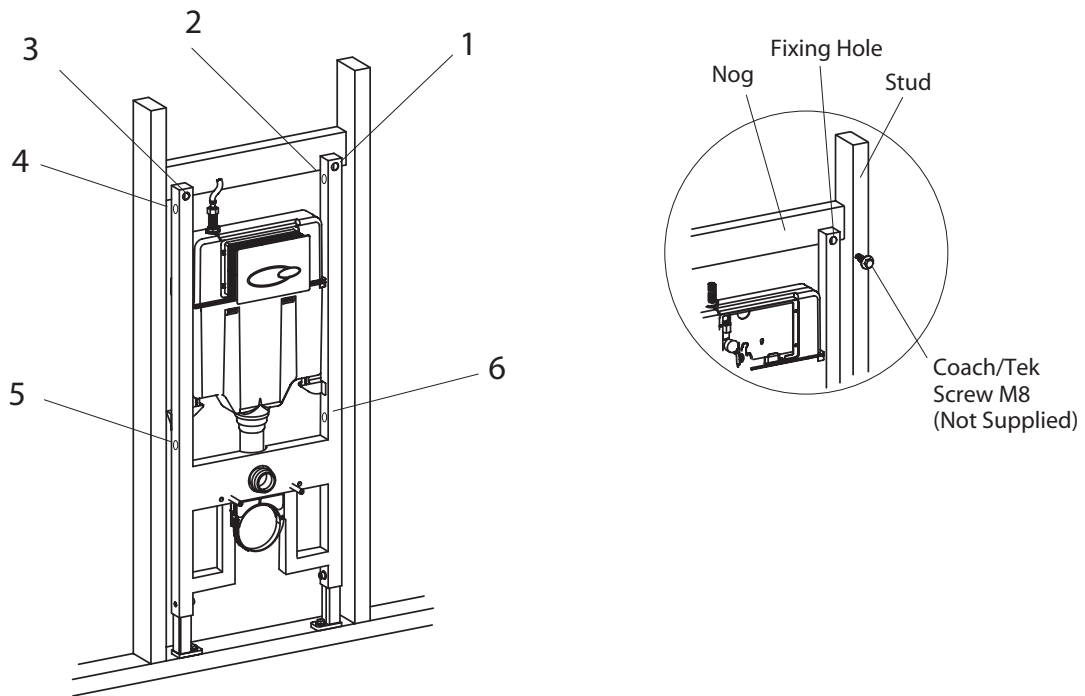

9. Loosen the waste pipe support if required. Fit the waste pipe connector tighten and lock the waste pipe connector support. Ensure the flush pipe and waste pipe are the correct height from the finished floor level, refer to the toilet manufacturers instructions and adjust if necessary.

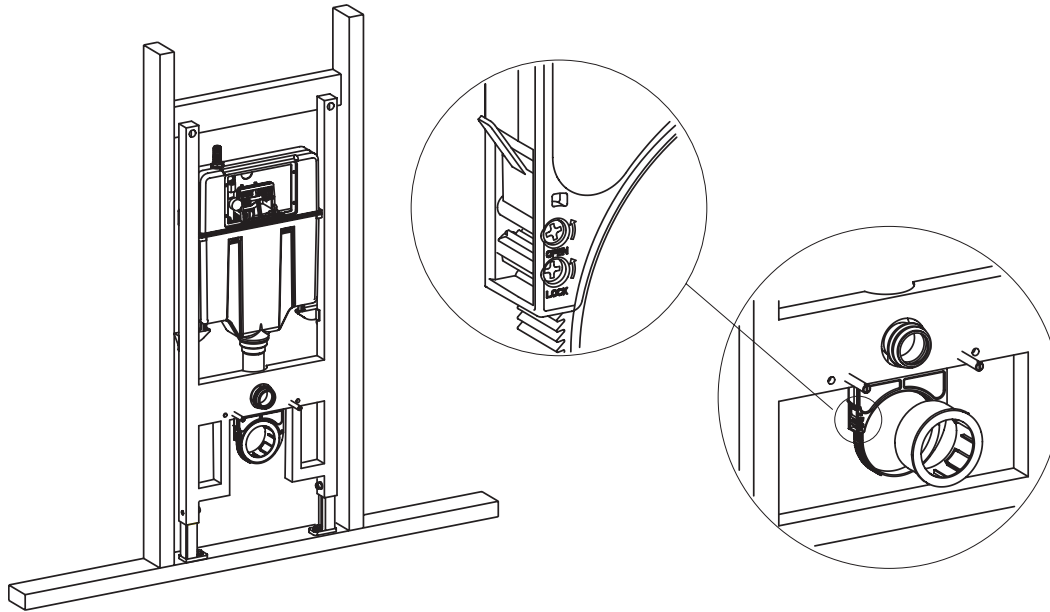

10. Fit the waste pipe and the flush pipe covers. Connect the water inlet hose (not supplied) to the tank water inlet.

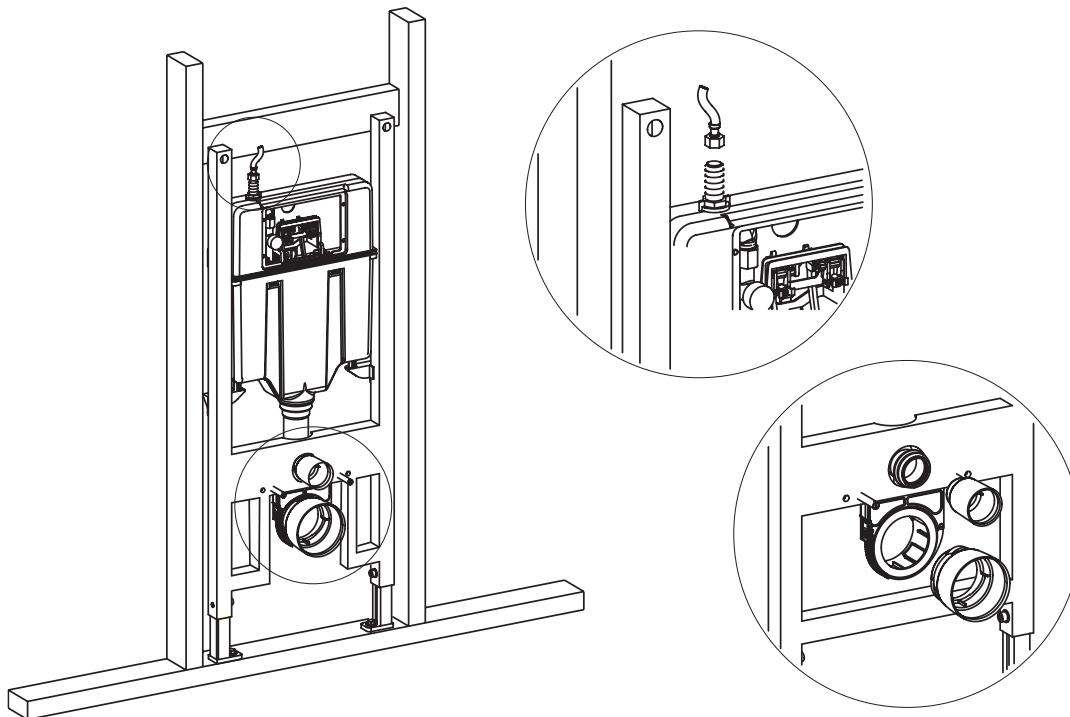

11. Screw the flush plate shield into position.

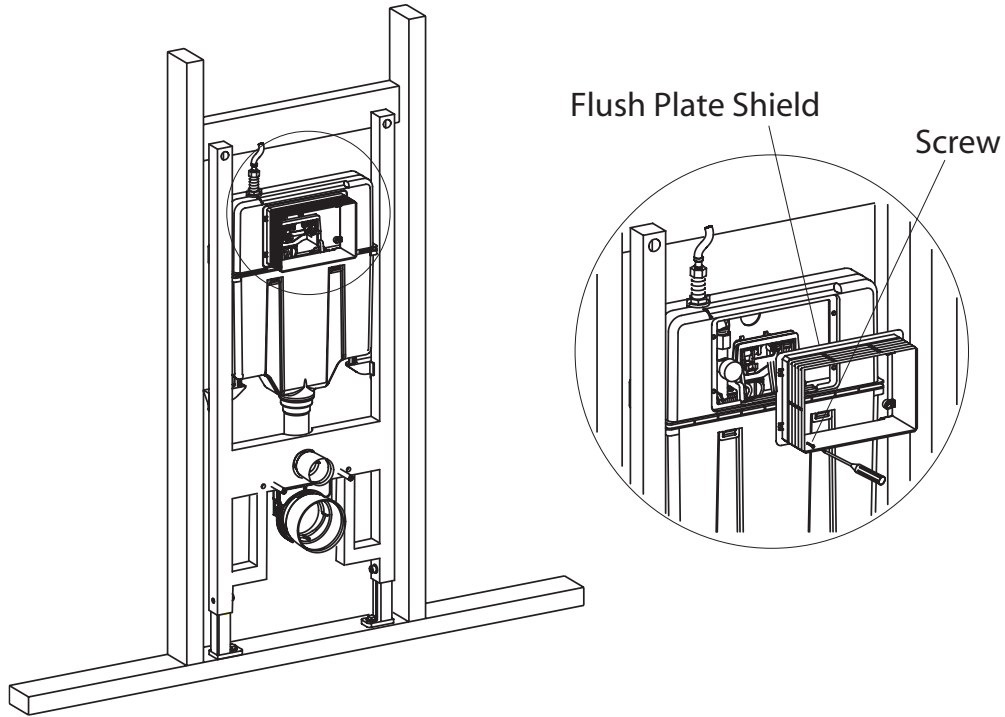

12. We recommend before cutting the gib board the toilet is fitted to the frame to verify the pan height is correct to the finished floor level. Cut the gib board to suit the position of the flush plate, waste pipe, flush pipe and toilet fixing holes. Fit the gib board to the stud.

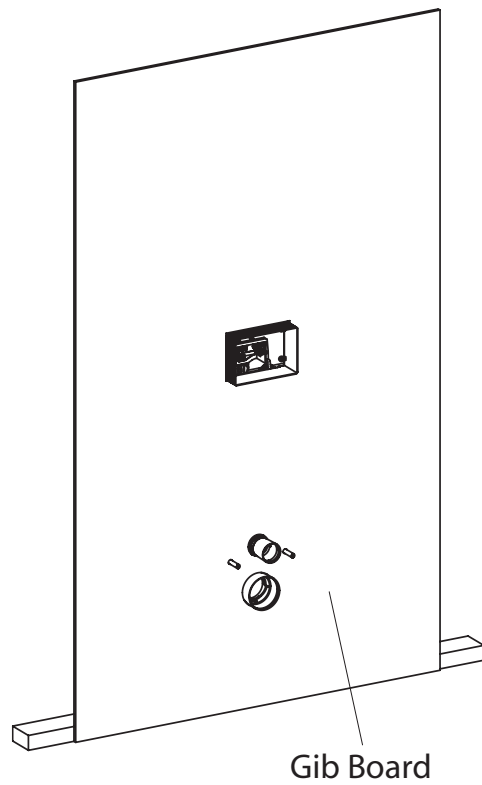

13. Using a sharp knife, trim the flush plate shield back level with the finished wall. If the finished wall is to be tiled please ensure the thickness of the tile is included. The trimmed Flush Plate Shield must sit flush with the finished wall.

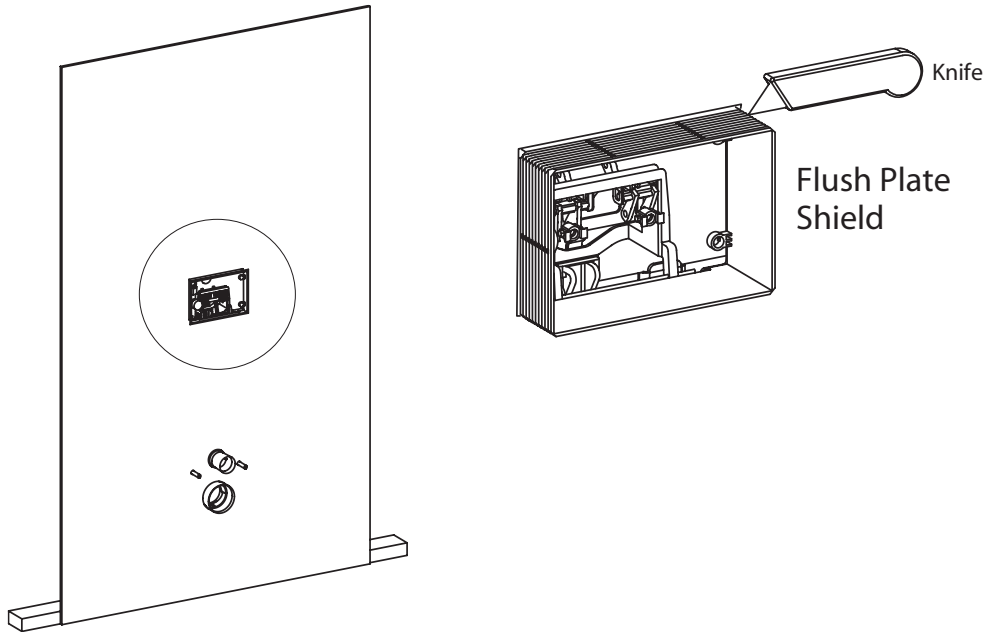

14. Remove the flush pipe and waste pipe covers.

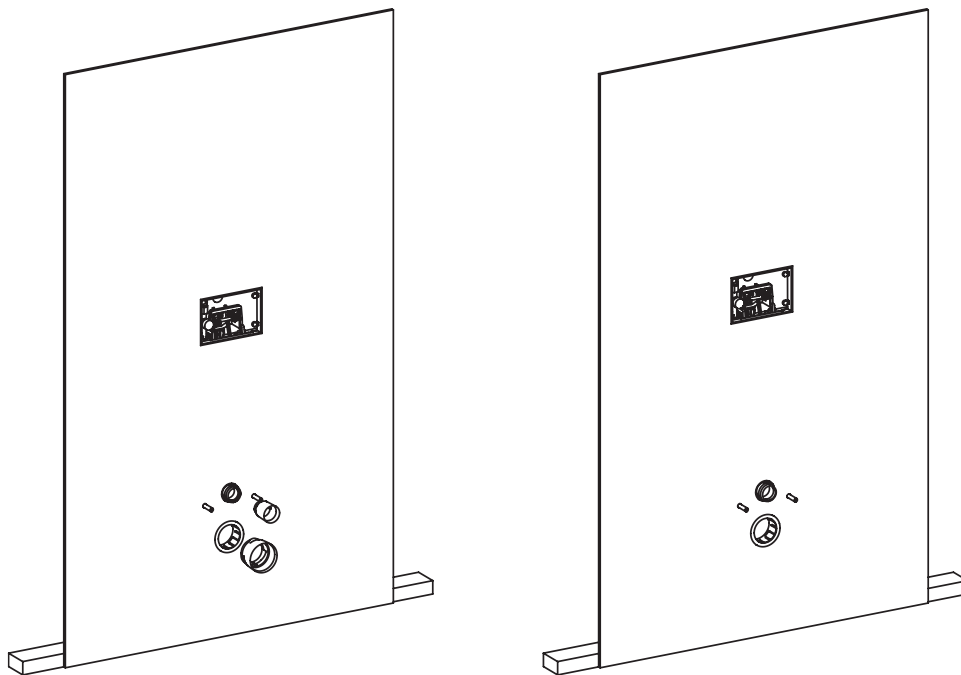

15. Fit flush pipe connectors and gasket to the flush pipe inlet on the toilet. Fit the waste pipe connector and gasket to the waste pipe outlet on the toilet.

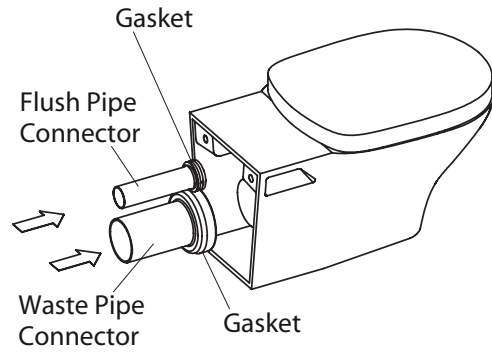

16. Mark on the pipe connectors the position of the rear of the toilet. Remove the pipe connectors.

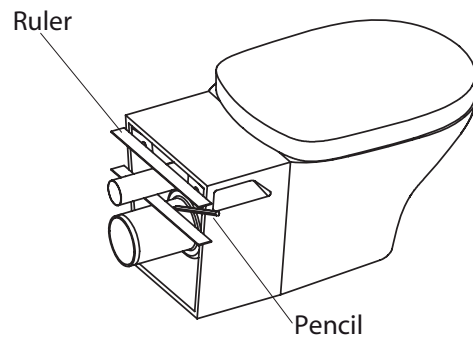

17. Mark on the pipe connectors a second line, which represents the connection distance required to connect the toilet to the flush and waste pipes within the wall. This connection distance is the distance between the rear of the tank and the hole in the gib board.

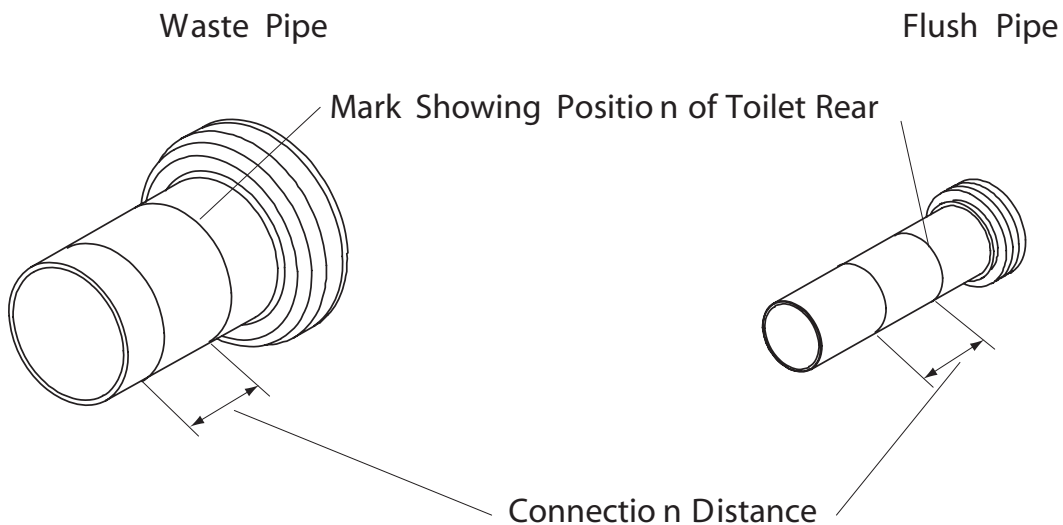

18. Cut both the waste pipe and flush pipe at the connection distance marks. Remove all burrs from the cut edges and reinstall on the toilet.

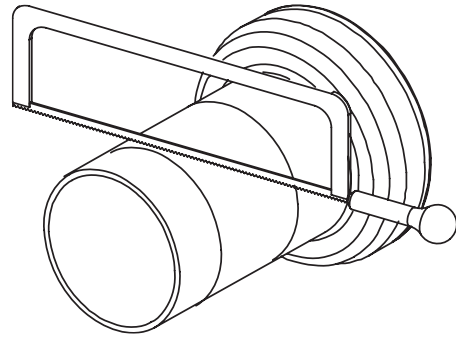

19. Place the toilet onto the fixing bolts. (Ensure the toilet is supported at all times.) Fit the rubber gasket, nut and decorative cap onto the fixing screws to secure the toilet in place.

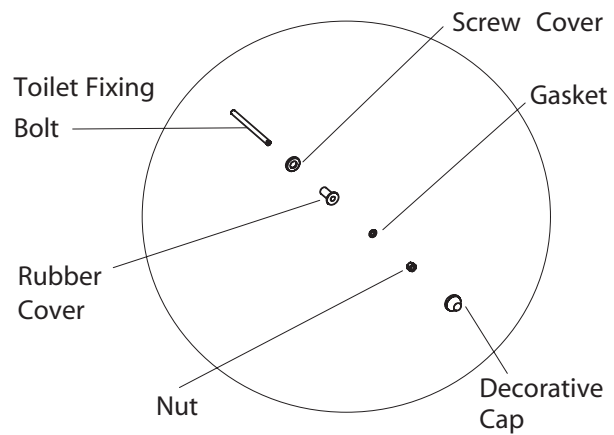
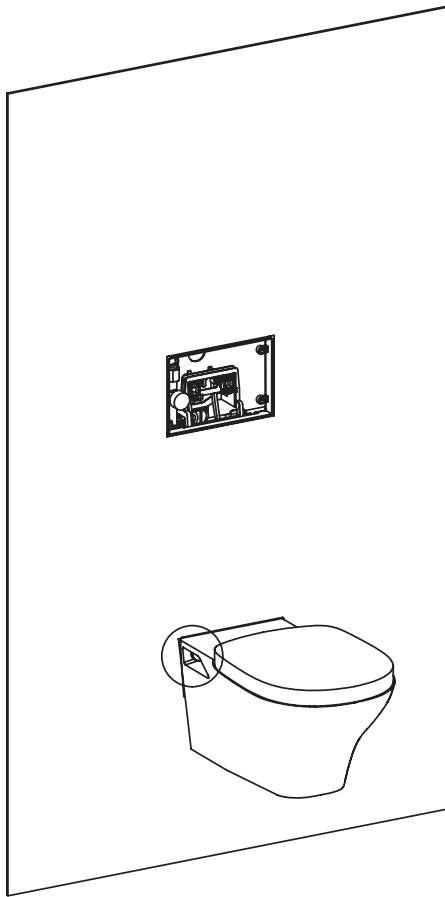

Flush button installation

20. Fix the locking plate to the flush plate shield using the plastic locking bolts. To lock the bolts in position turn the bolt until the tab on the bolt head is vertical. Trim the length of the locking bolts if required.

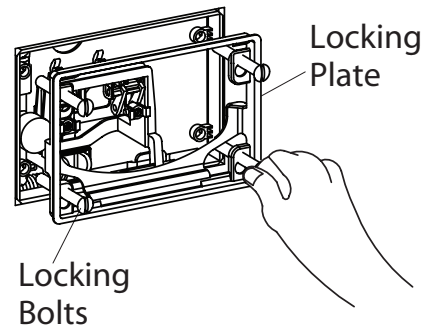

21. Screw the flush rods into the flush actuator until the unthreaded end of the rod is flush with the locking plate. Ensure the flush rod is secured through the square holes at the rear of the flush actuator.

Test the flush action to ensure it is moving smoothly.

Adjust the flush rod as required then tighten the lock nuts to prevent adjustment while in use.

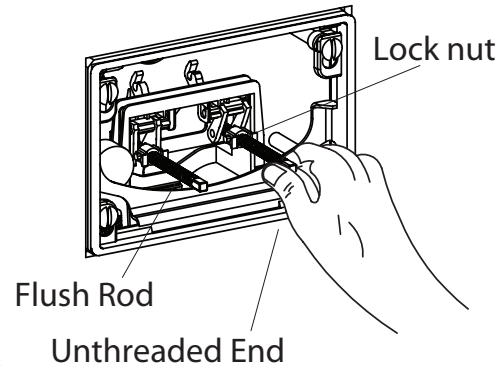

22. With the cover positioned as shown, with the large button on the left hand side. Place the tabs of the cover on the bottom edge of the locking plate and push the cover into the position. Ensure the flush button operate smoothly.

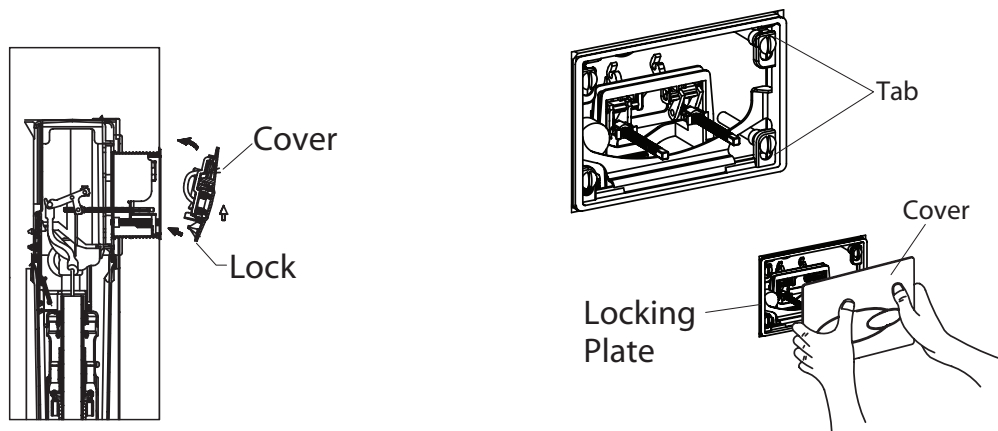

23. In-wall tank toilet is ready used.

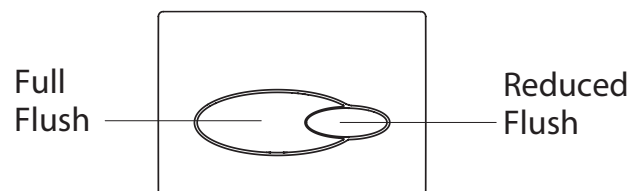

Remove and Maintenance of Outlet Valve

1. Hold the cover with both hands and push upward. Rotate the top of the cover away from the wall to release.

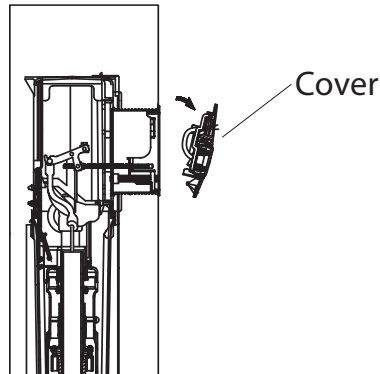

2. Unscrew the flush rods.

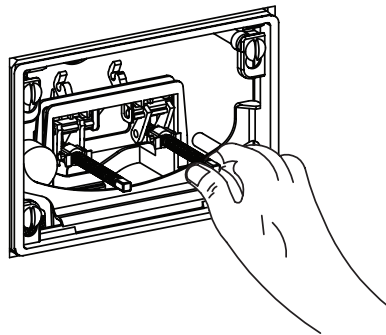

3. Turn the lock bolt to the OPEN position and remove the locking plate.

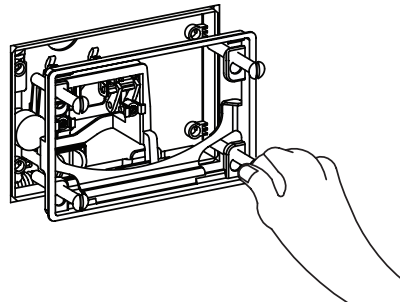

4. Unhook the 2 valve legs from the flush actuator.

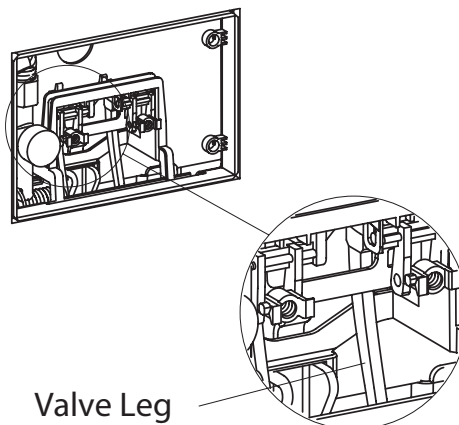

5. Lift the flush actuator upwards to release it from the tank and remove.

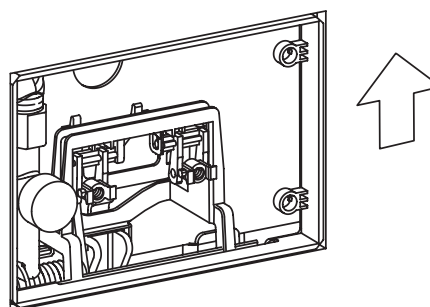

6. Turn the water off at the shut off valve inside the tank. Unscrew the fill valve fixing nut and remove the fill valve.

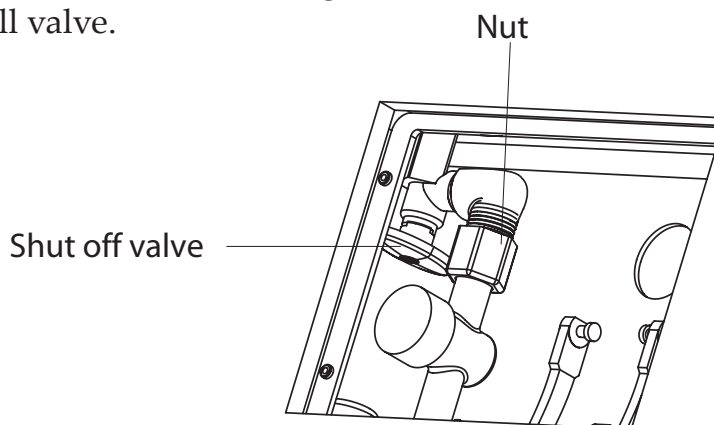

7. Note the orientation of the flush valve legs. Remove the legs from the flush valve by unhooking the base of the leg from the flush valve.

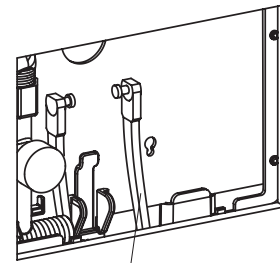
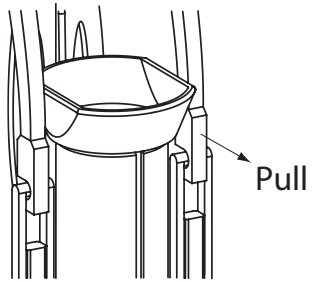

Flush Valve Leg

8. To release tab securing the flush valve by pulling it towards you. Rotate the flush valve anti clockwise to release it from the base.

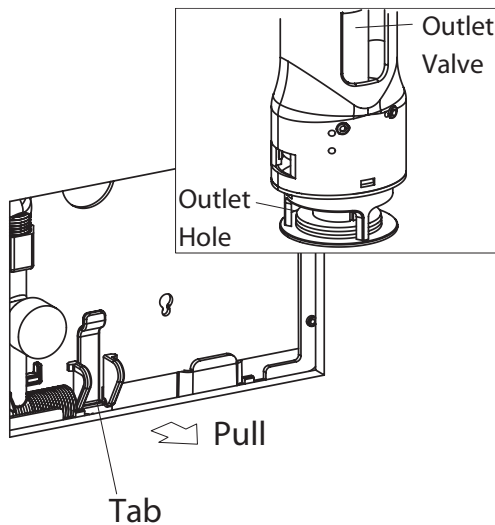

9. Lift the flush valve assembly including the securing tab up until the valve and tab can be held. Separate the tab from the flush valve by pulling it upwards. Remove the tab from the tank.

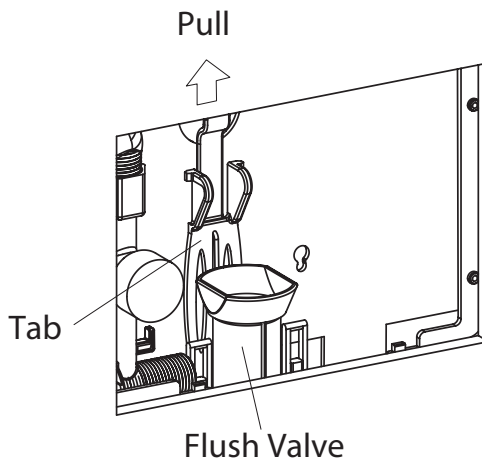

10. Lift and rotate the flush valve until it is horizontal.

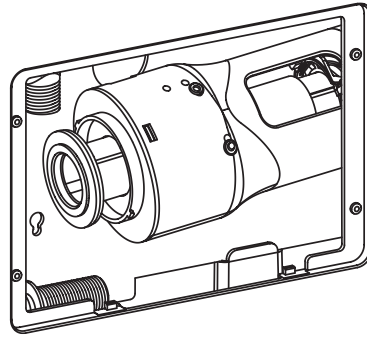

11. Rotate the base of the flush valve out through the access panel.

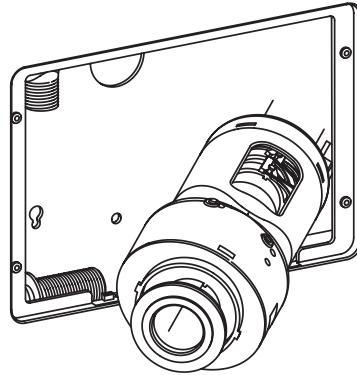

12. To replace the flush valves follow these instructions in reverse order.

Flush Valve Adjustment.

Full Flush:

Adjust the position of the switch on the valve side to vary the full flush volume.

Reduced Flush:

adjust the position of the float to vary the reduced flush valve.

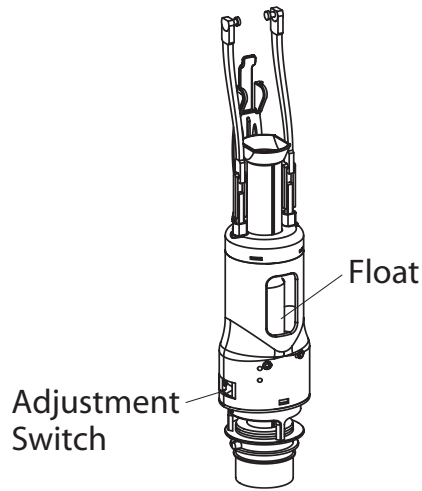

Inlet Valve Adjustment.

Turn the screw anti clockwise to reduce the water level.

Turn the screw clockwise to increase the water level.

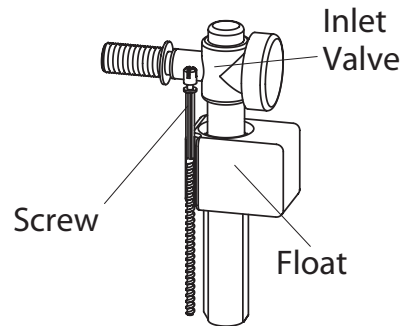

Trouble Shooting Procedures

Symptoms	Probable Causes	Recommended Action
Tank not filling	The shut off valve is closed	Open the shut off valve
	The inlet valve float is stuck	Adjust the inlet valve to an appropriate position
	The inlet valve is filter is blocked by debris	Remove the inlet valve and wash out the filter
Flush not operating	The flush rods require adjusting	Adjust the flush rods
	Flush valve legs are disconnected	Ensure the flush valve legs are installed in the correct orientation and connected correctly
Water level too high or low	Float level of the inlet valve requires adjusting	Adjust the inlet valve float level
Tank does not stop filling	The inlet valve float is stuck	Adjust the inlet valve to an appropriate position
	The outlet valve is not sealing correctly	Uninstall the outlet valve, check the seal, replace if warn. Remove any debris and reinstall.

Service Parts

1. 1112165 Flush Valve.



2. 1112166 Flush Valve Gasket.



3. 1112167 Flush Valve Legs.

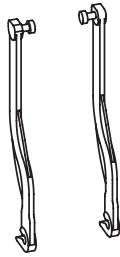

4. 1112168 Security Tab.



5. 1112169 Flush Actuator.

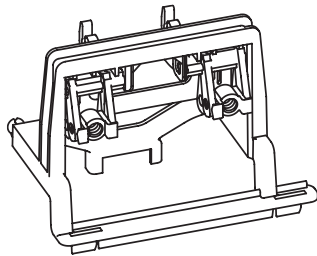

6. 1112170 Flush Rods.

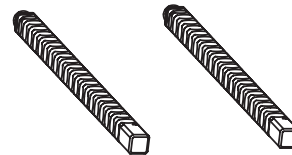

7. 1112171 Fill Valve.

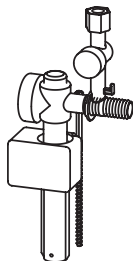

8. 1112172 shut off Valve.

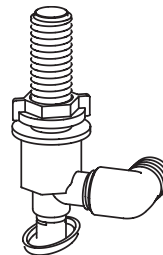

9. 1112173 Button Sheild.

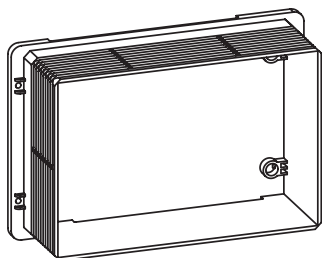

10. 1084946 S Trap

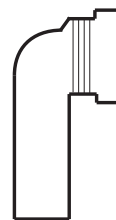

Service Parts (continued)

11. 1112175 Waste Pipe Holder.

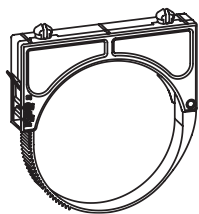

12. 1112176 Waste Connector.

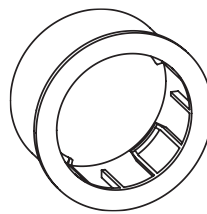

13. 1112177 Waste Pipe.

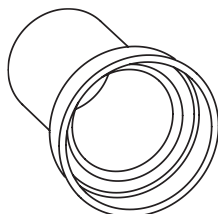

14. 1112178 Waste Gasket.

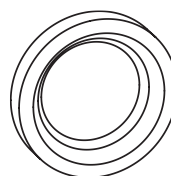

15. 1112179 Water Inlet Pipe.



16. 1112180 Water Inlet Gasket.

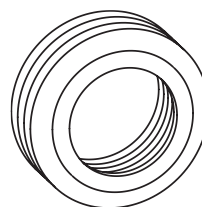

17. 1112181 Fixing Nut Assy.

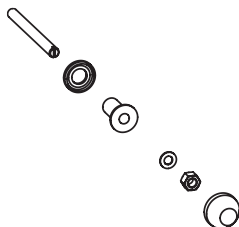

18. 1112182 Tank Gasket.

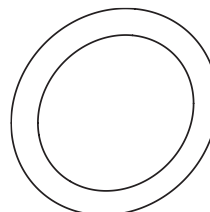

19. 119206 Locking Plate.

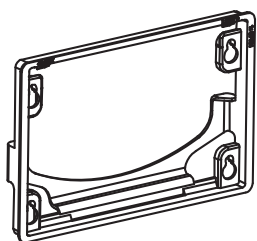

20. 1059169 Locking Plate Bolts.

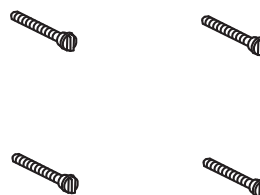

CONTACT AND WARRANTY INFORMATION

For warranty information, please visit our website

Australia

www.au.kohler.com

New Zealand

www.kohler.co.nz

KOHLER

CALL US FOR HELP

NEW ZEALAND
KOHLER NZ LTD

Free Ph: 0800 564 537 (0800 KOHLER)
Free Fax: 0800 664 488
www.kohler.co.nz

AUSTRALIA
KOHLER CO.

Free Ph: 1 300 362 284
Free Fax: 1 300 652 284
www.au.kohler.com