

DESIGN STORIES

RE
E
H
O
K

Table of Contents

TERRACE™	4
VEIL™	10
BRIOLETTE™	14
DERRING™	18
REVE™	22
MARGUAX™	26
ARTIFACTS™	30
AVID™	34
COMPOSED™	38
PURIST™	44
LOURE™	48
STANCE™	52
ALEO™	56
KUMIN™	60
KOHLER DESIGN STUDIOS	64

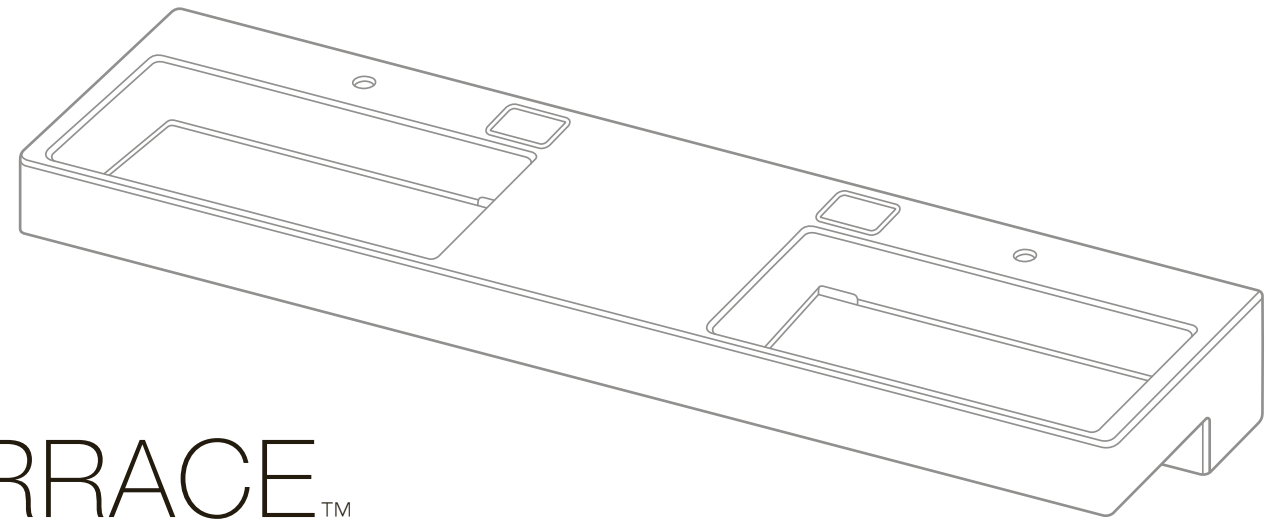

TERRACE™

The design exploration that led us to the Terrace bathroom sink stemmed from a series of insights we uncovered during extensive research surrounding modern styling spaces and today's evolving grooming rituals.

The Kohler Paris design studio began by pursuing a pure, elemental form that when paired with cabinetry would appear less overtly task-oriented and feature a silhouette more akin to a contemporary bureau. Our insights indicated a developing desire for bathrooms that skewed more comfortable and living-roomesque.

This notion of purity prompted the team to consider an alternative placement for the center drain and to reimagine the basin as a smooth, uninterrupted surface. Instead of a traditional drain, we integrated an entirely new slotted drain system and

touch-pad control into the back of the sink. The move resulted in a clean, rectangular form with the added benefit of shifting the drain out of the way of prime storage space beneath the basin.

Adding the iconic L shape allowed us to conceal the plumbing and introduce a unique storage solution positioned between the sink and cabinet. Depending on individual preference, this space can be left open or finished with a slim drawer that invites a simple arrangement of beauty and self-care items. This layered approach allowed the Paris

team to address changing storage needs based on new styling rituals: the shallow drawer accommodates daily-use items that require quick access while the cabinet's deep drawers contain those items in less frequent rotation.

Ultimately, Terrace is about absolute simplicity, in form and function. There is a familiarity in the basic geometry, but it reveals itself to be an evolved, layered design. Today Terrace is available in a number of standard sizes including a 150 cm double-basin model.

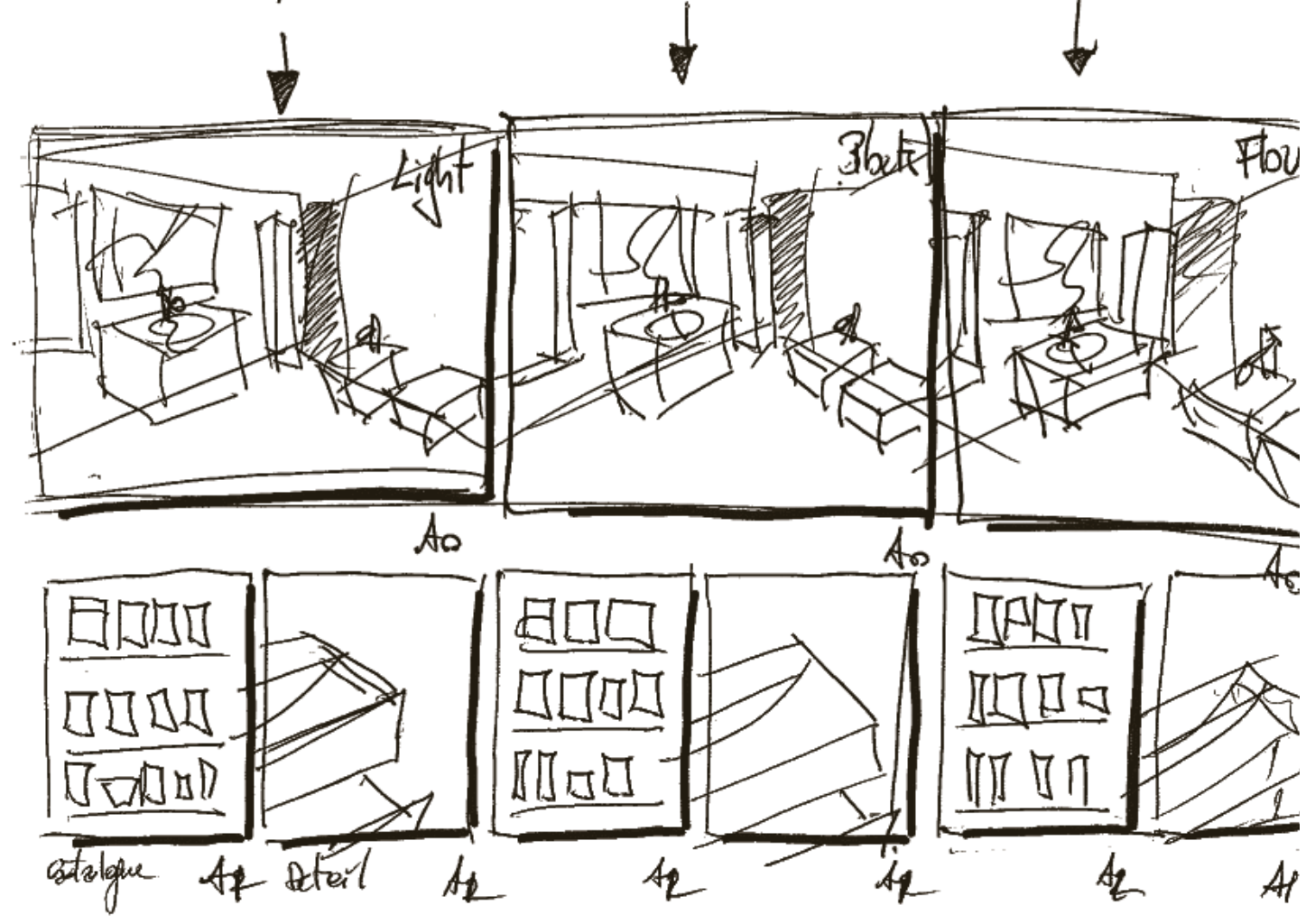
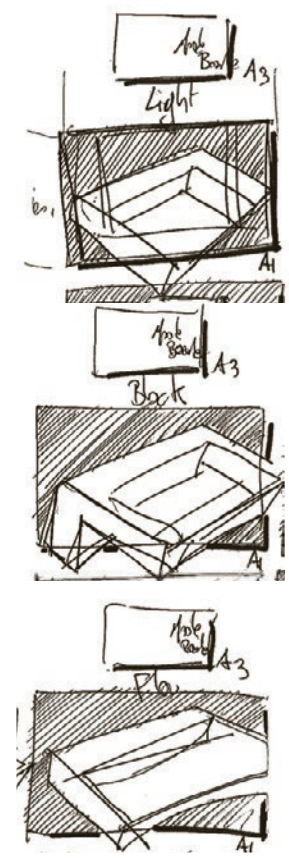
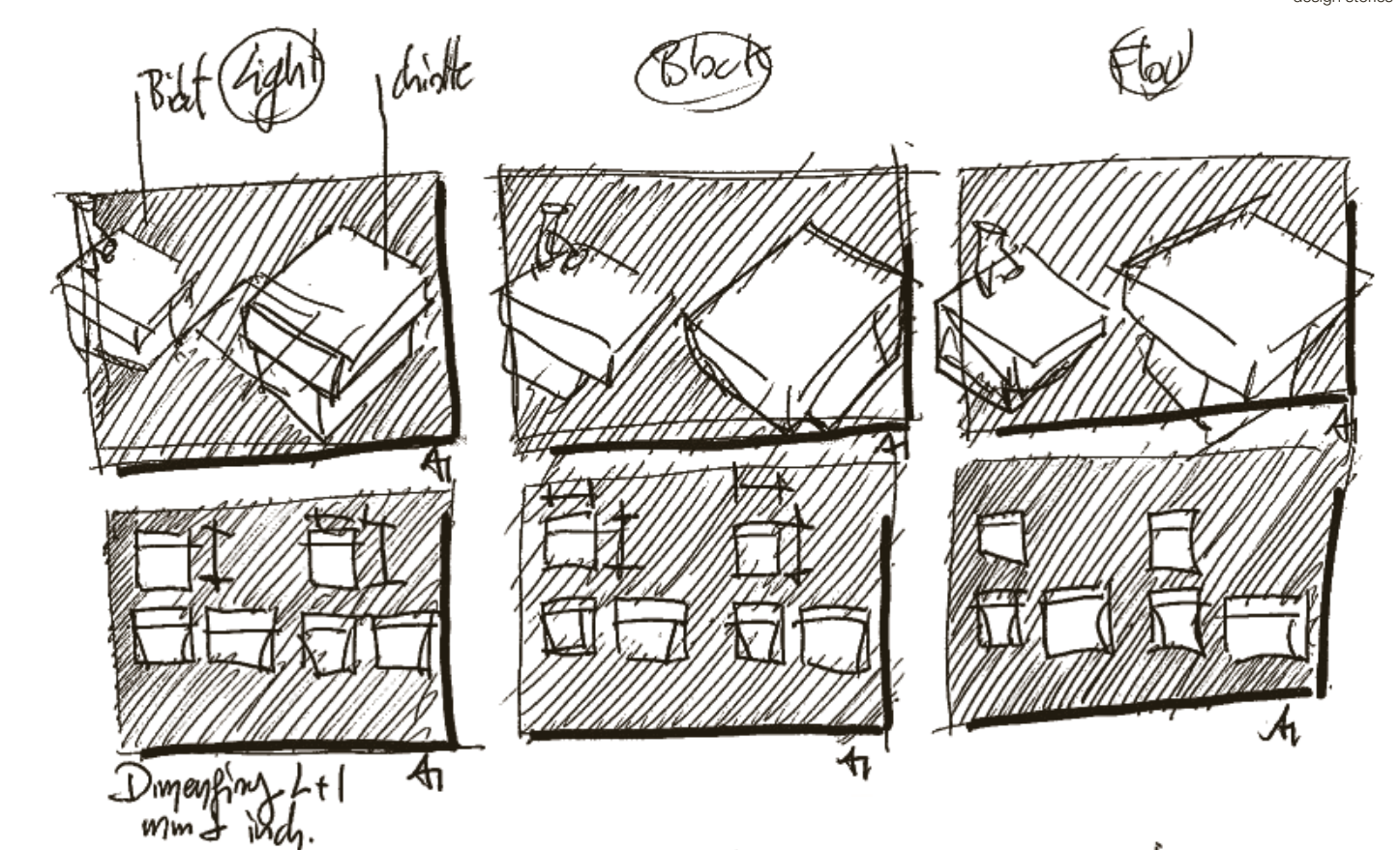
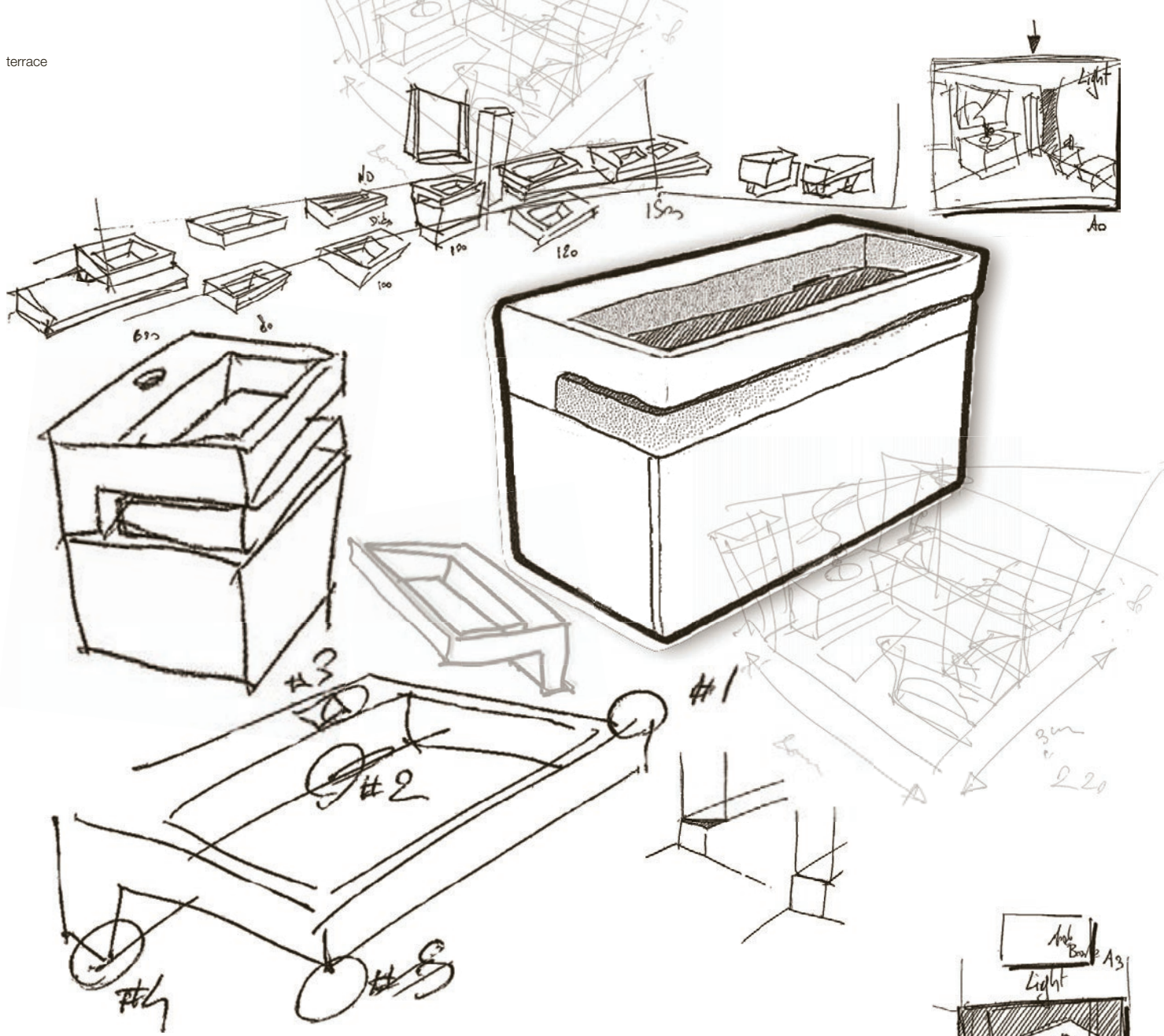

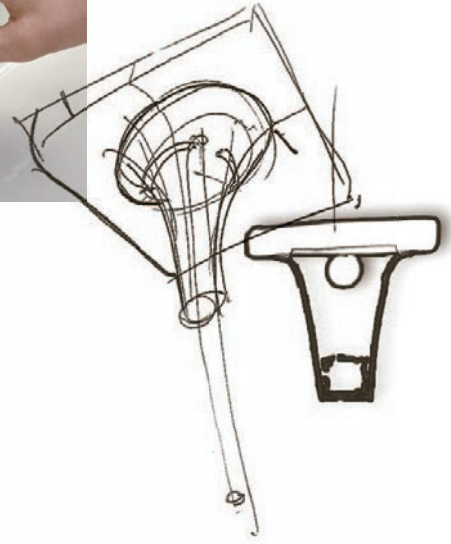
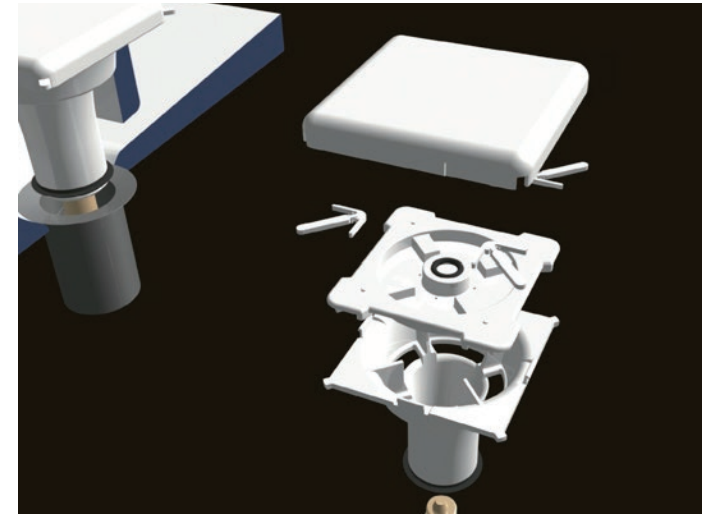
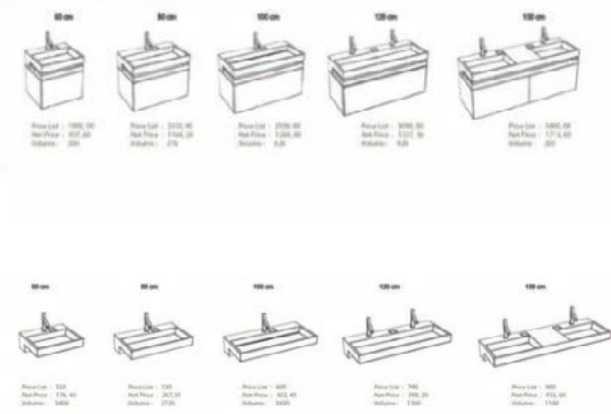

The home should be the treasure chest of living.
LE CORBUSIER

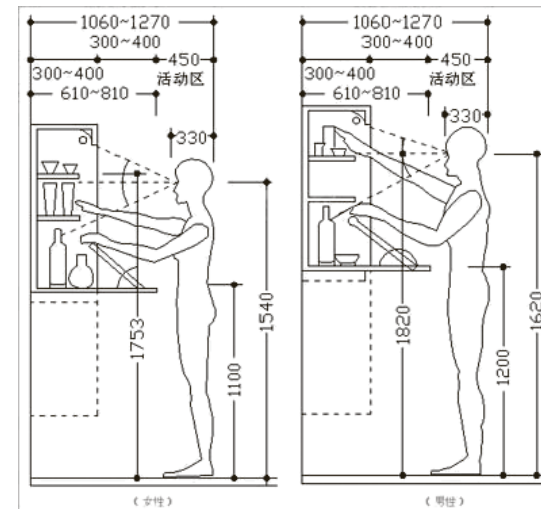
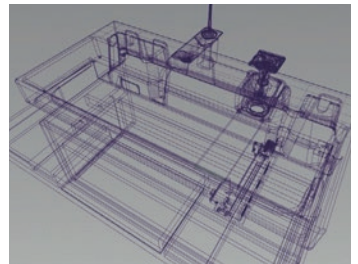
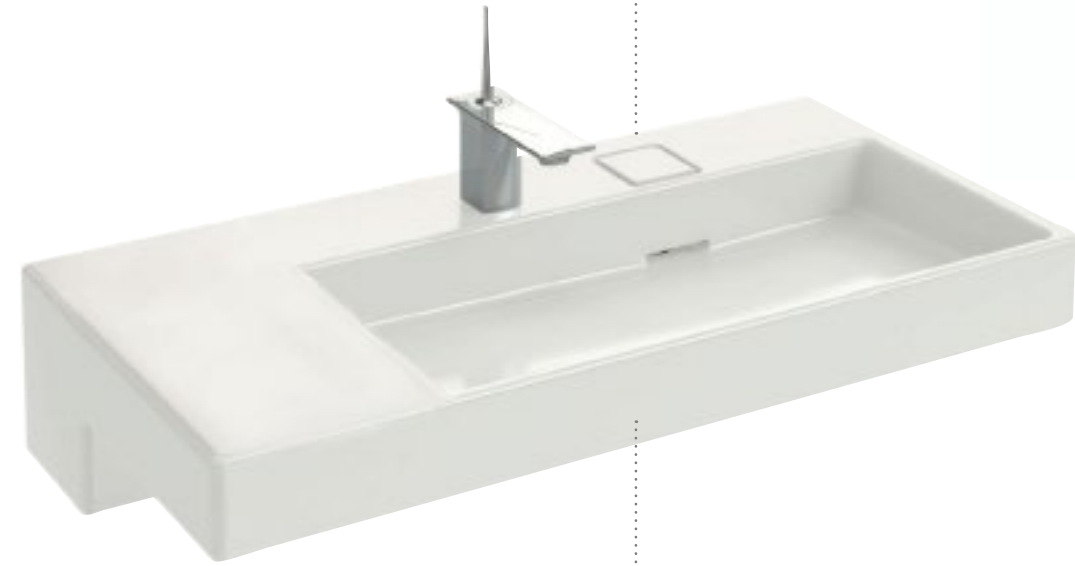

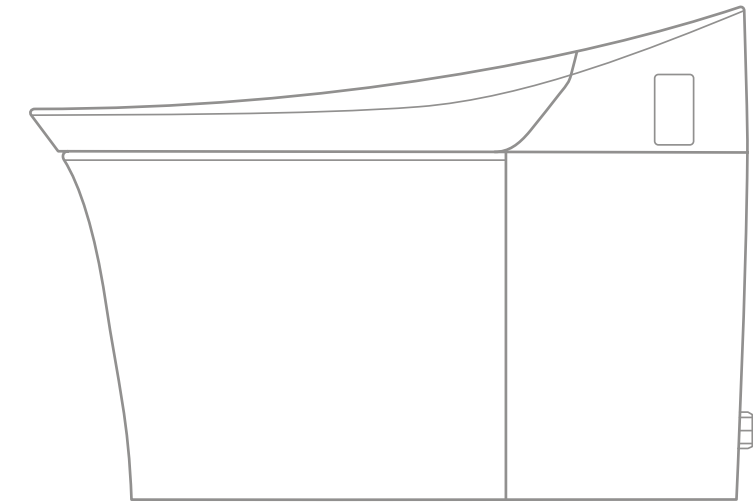

VEIL™

The China studio team launched the Veil project to address space saving tankless toileting with ultra responsive bidet functionality.

However, the team was also determined to refine and soften the existing profile of contemporary tankless toilets, to disrupt the current expectation.

With the relatively recent architectural phenomenon of the Cape Town Stadium still fresh, the design team drew on its sculptural simplicity and sophistication to inform the design vernacular of Veil. As a result, Veil marries unexpected artfulness with advanced technology for a visual

and experiential seamlessness. Flipping the popular domed profile on its head, Kohler China designed a slightly bowed seat cover with a very tight corner radius that captures the elegance of precision. The lift at each end is evocative of the lines of a sailing vessel and gives the design a surprising lightness. Combining sleek design with incredible personal comfort and control sets the Veil toilet apart. It is the perfect marriage of technology and art.

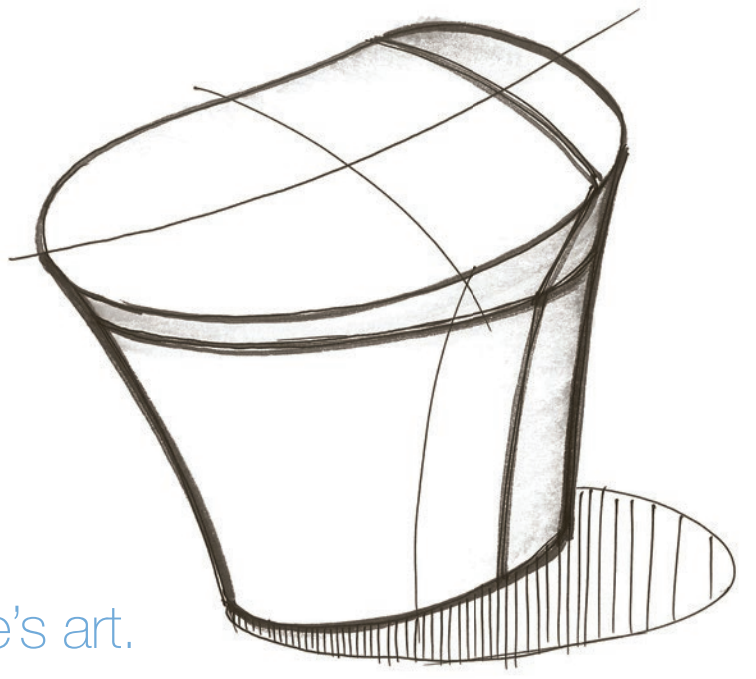
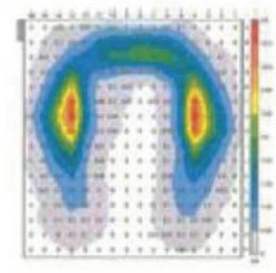
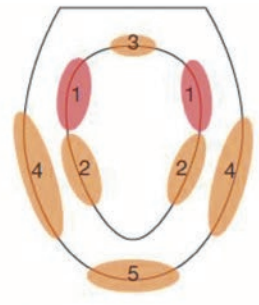
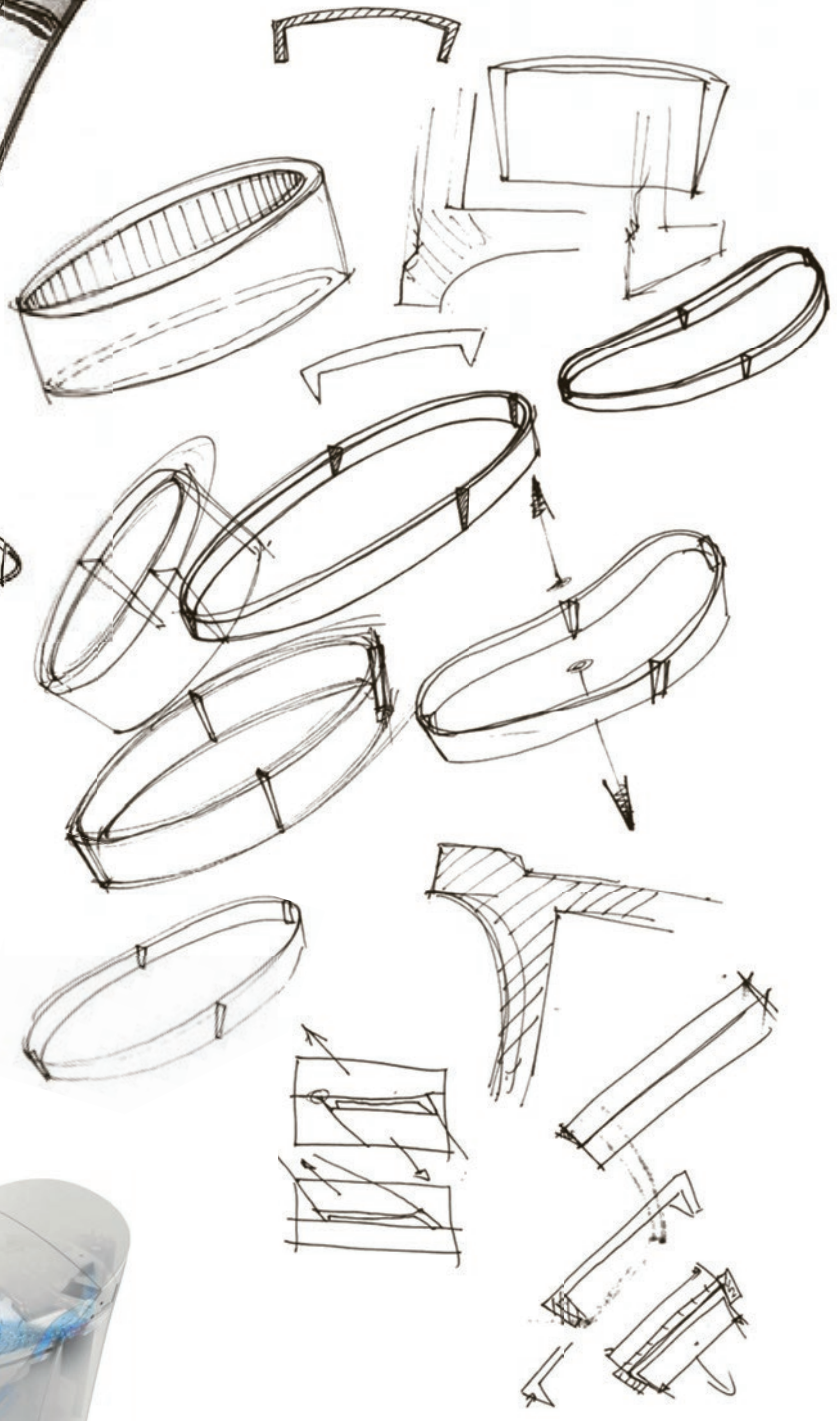
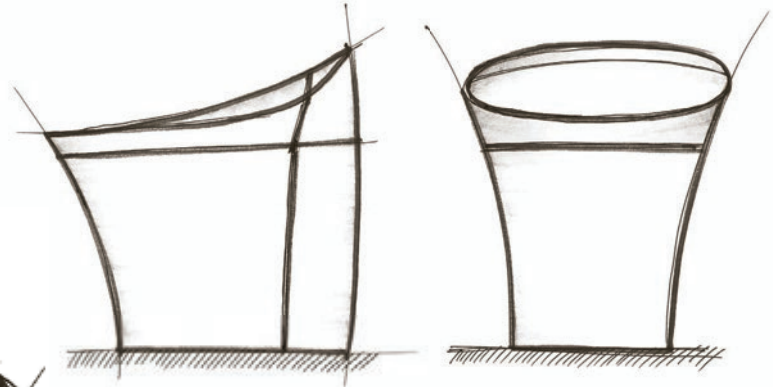

There's design, and there's art.
 Good design is total harmony.
 DIANE VON FURSTENBERG



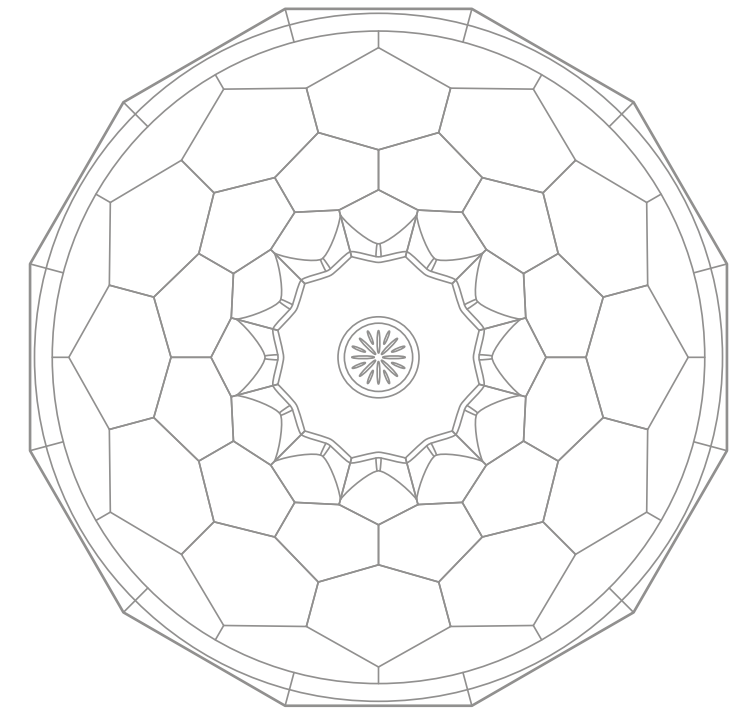

BRIOLETTE™

At the time Briolette was being designed, the Kohler U.S. design team was still exploring the potential of their newly established glass studio. They were still discovering the possibilities and limitations of the glass itself, so the window of opportunity was fairly wide open.

Turning to a variety of inspiration points, the lead designer began by studying faceted glass forms, from antique decorative crystal and cut diamonds to modern architecture. Drawn to the highly contemporary structure of the Beijing National Aquatic Stadium, she eventually narrowed her focus to working with the hexagonal shape that gives Briolette its distinctive design.

The small team of designers and glass artisans experimented with prototypes of spun glass molds, playing with the scale and repetition

of the hexagon to find a balance that showcased the true beauty of the material. While the glass studio works with cast, pressed and slumped glass as well, spun glass was used to achieve the incredible depth of dimension in the facets while still preserving the function of a smooth interior surface.

One of the benefits of the small glass studio is the collaboration that occurs between the designers and the glassmakers themselves during prototyping. The scalloped edges of Briolette were a direct

result of that collaborative effort – an unexpected discovery when the mold stopped short that became a dominant element in the design.

Briolette, with its interlocking geometric pattern, has a uniquely modern sensibility that plays equally well against a minimalist backdrop or accompanied by classical detail. Today we have expanded the Briolette line to include four distinctive translucent hues.

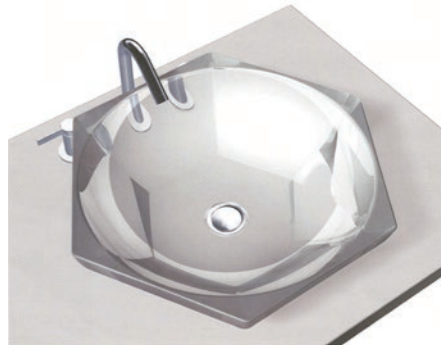
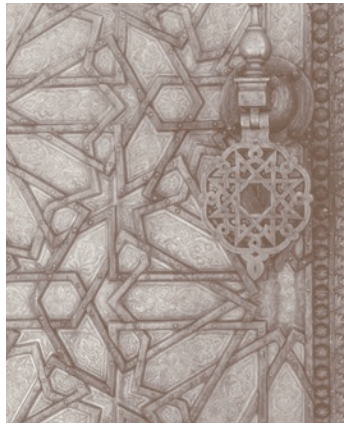

Glass is the most magical of all materials.
DALE CHIHULY

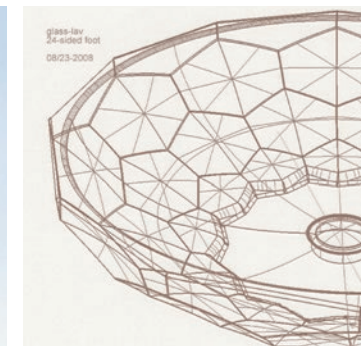
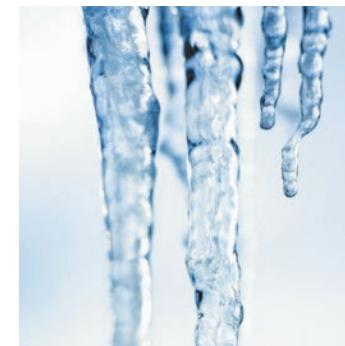
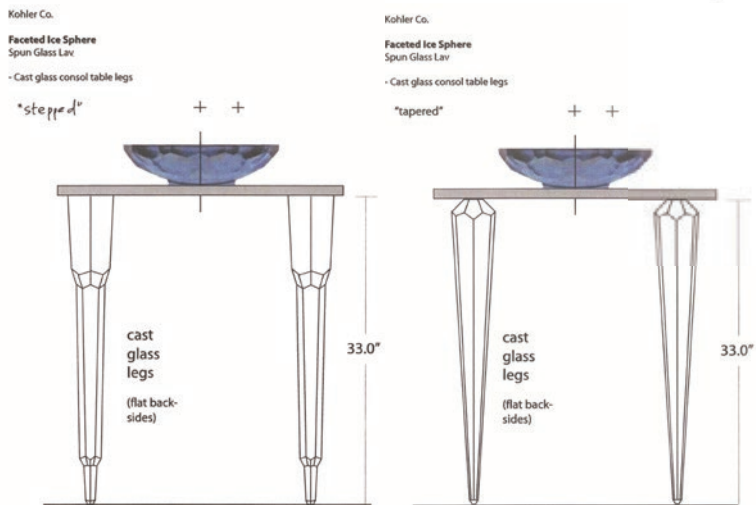
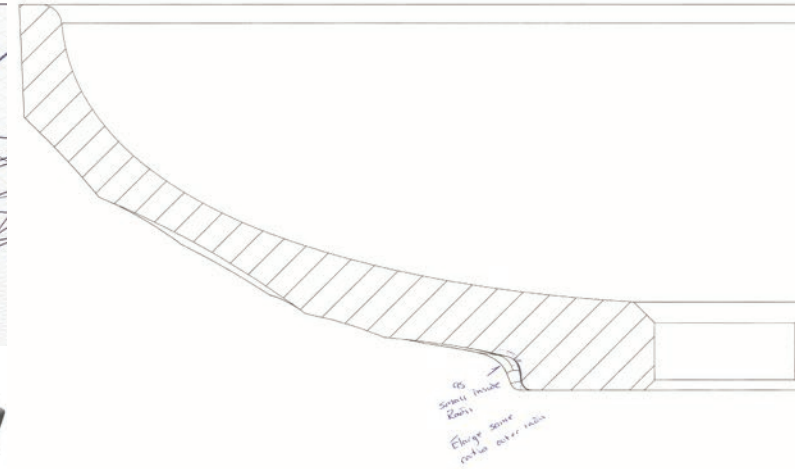
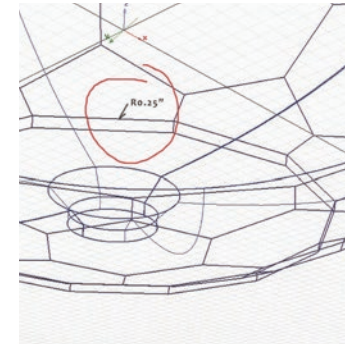
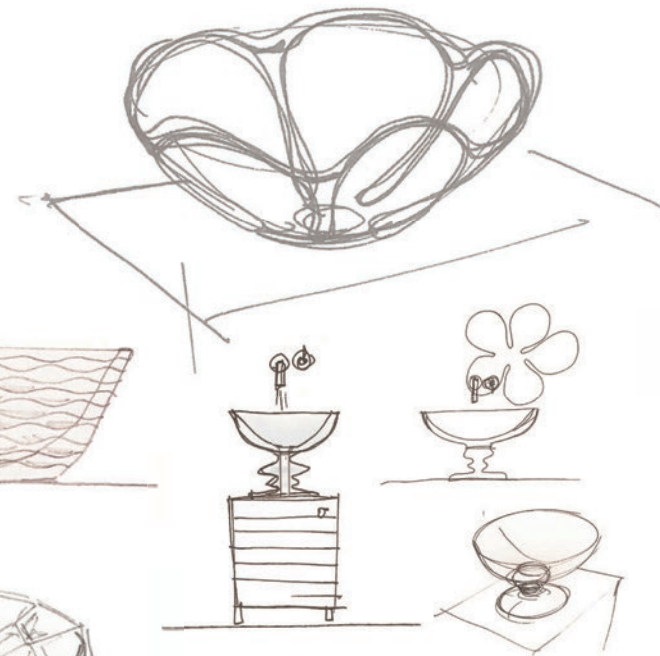
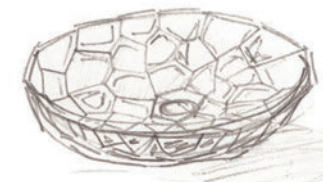
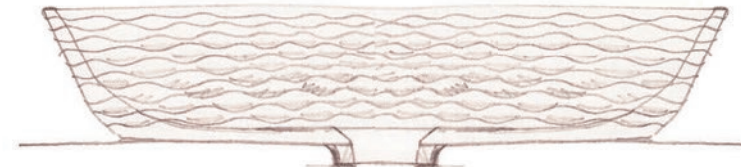
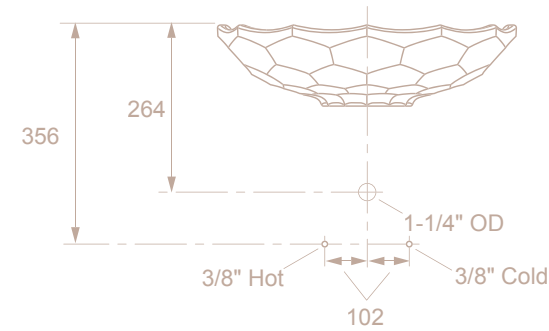
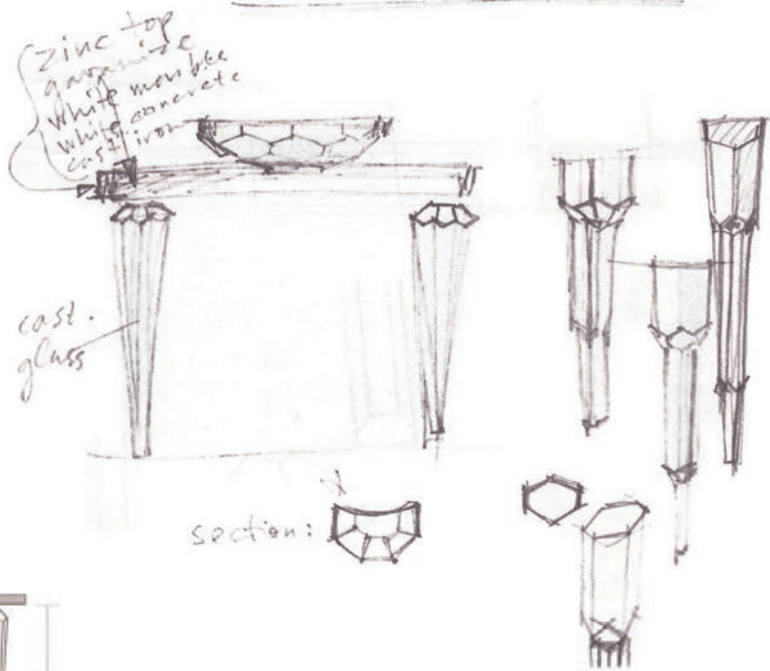
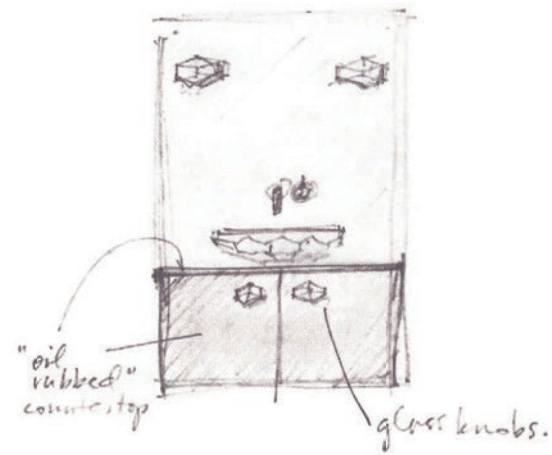

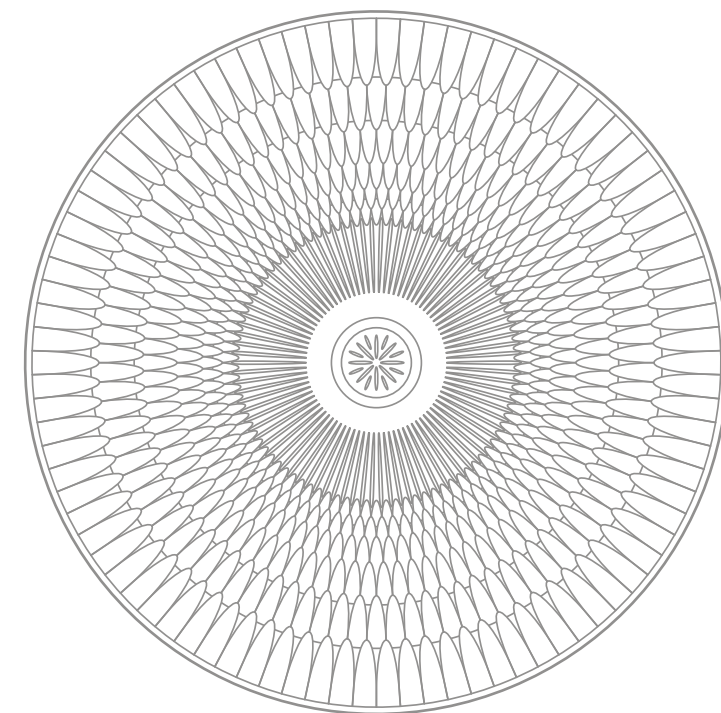

DERRING™

We set out to take the very best of what the Artist Editions™ collection stands for and tap into the craft-forward movement at the forefront of design.

After a broad initial exploration of studio pottery and the methods used, we narrowed our efforts to working with rutile glaze, a highly unpredictable artisan glaze that creates a dimensional effect as it rakes over a surface. Ironically, what makes rutile glaze so difficult to work with is also what makes it so appealing. The way the fired glaze shifts across the ceramic creates a unique depth of color. When water pours over the pattern, its reflective qualities highlight the subtle tonal differences even further.

Additionally, while rutile's association with the craftsman glazes of the American Arts & Crafts movement seemed particularly well suited to our goals, creating a repeatable glazing process that could be scaled from the studio to manufacturing was no small feat. The challenge was three-fold: developing a glaze with the right flow consistency; carving the scoops to a pitch and depth that would allow water to drain freely without pooling; and casting a new basin shape to achieve a graceful lift from the countertop.

Based on our color research and the palettes we've identified as significant to bathroom design, in particular neutrals, earth tones and coastal blues and greens, we've expanded the color selection. The collection now includes Bourbon, a rich brown with copper highlights; Bluestone, a soft, layered blue; and Translucent White. Derring's hand-crafted design puts one-of-a-kind artistry at the center of contemporary bathroom settings.

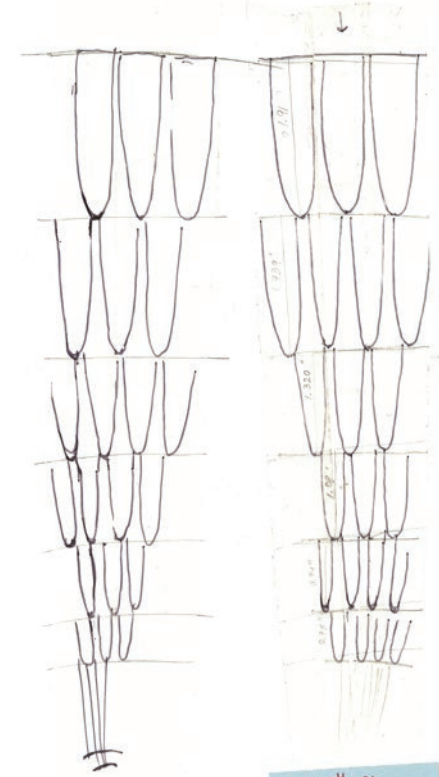
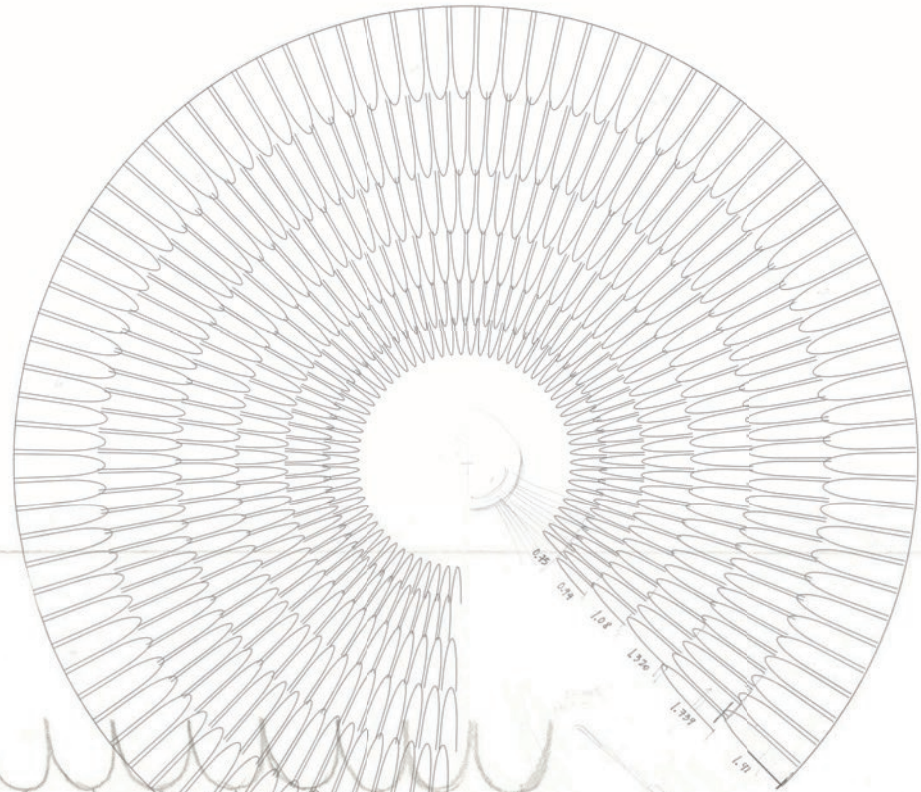
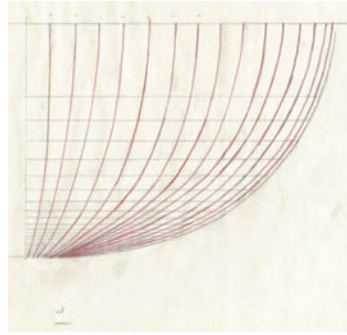
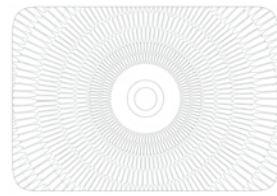

- 1- depth of pockets
- 2- size of pockets
- 3- Drain lines depth?

What art offers is a space
— a certain breathing
room for the spirit.

JOHN UPDIKE

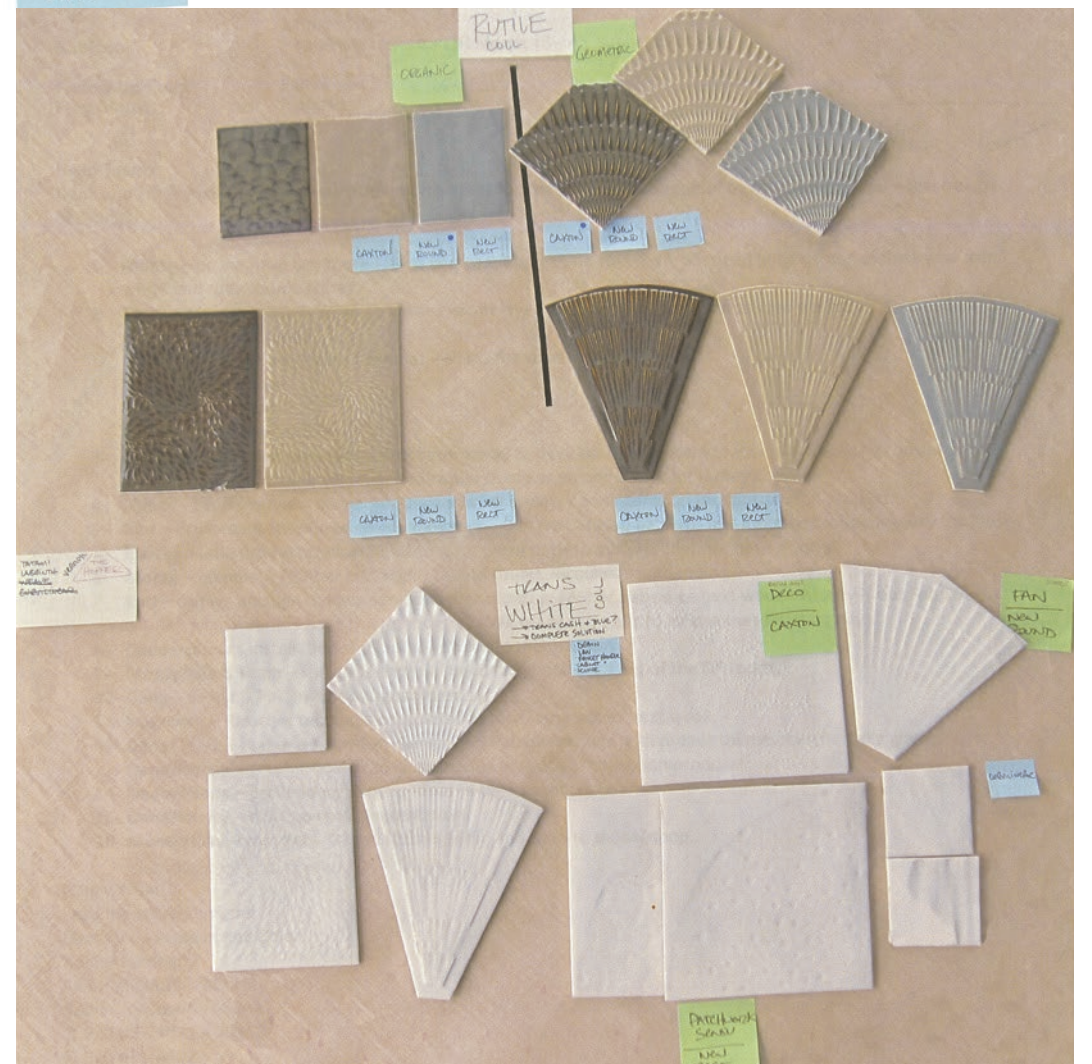
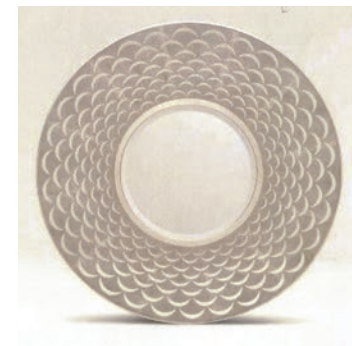
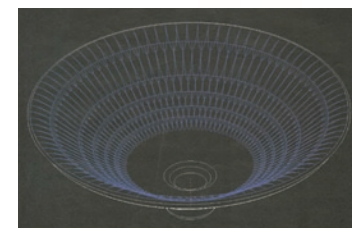
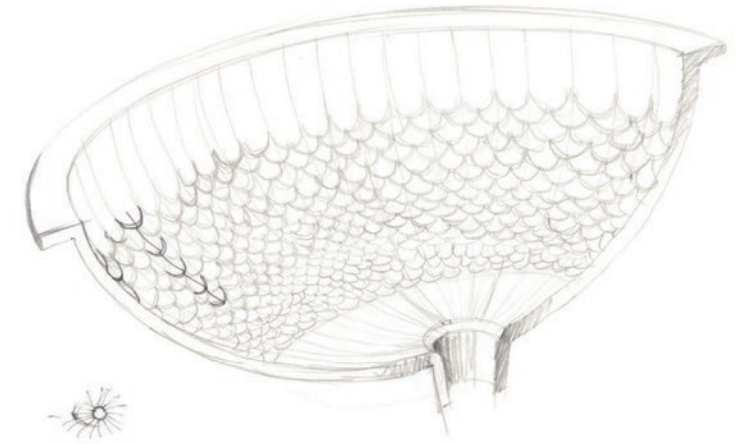

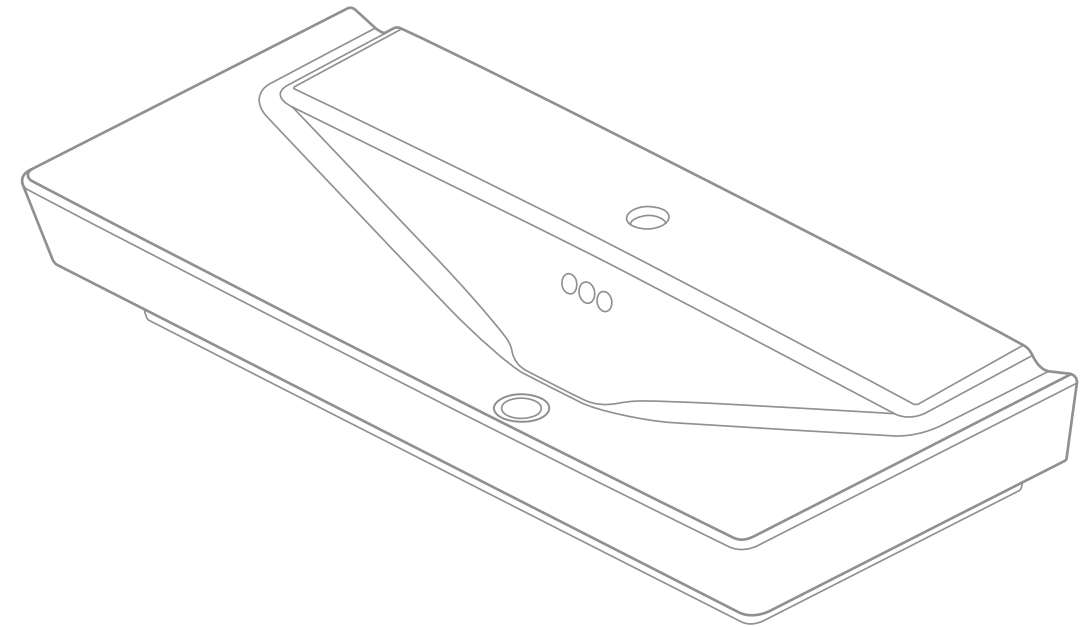

RÊVE™

As we developed designs to build out our contemporary collections, we saw opportunity to push the material limitations of ceramic. Rectilinear shapes are by far the most difficult to produce consistently in vitreous china, so achieving the long, straight lines that characterize modern design became the primary challenge in creating the Rêve collection.

Our exploration began with the signature 100 cm vanity top and accompanying cabinet. Eliminating ornamentation and purely decorative elements, we drew on the minimalism and utilitarian essentialism of Bauhaus design. This focus on function led us in turn to expand the basin to the entire area of the vanity top, increasing the usable space of the sink and redefining the relationship between the basin and functional deck area. The functional deck area became instead an island within the basin, set off by deep v-shaped channels at the back edge of the sink.

To resolve concerns that, given its length, the edge of the vanity top may not be flush with the cabinet, we added a recessed base along the sink to create a uniform, visually arresting gap where the two connect.

At its heart, the Rêve collection is a celebration of the simple beauty found in clean lines. We pared individual pieces down to their essentials, extending lines and seamless surfaces to accentuate the sculptural geometry and purity of each piece.



You begin with the possibilities of the material.
ROBERT RAUSCHENBERG

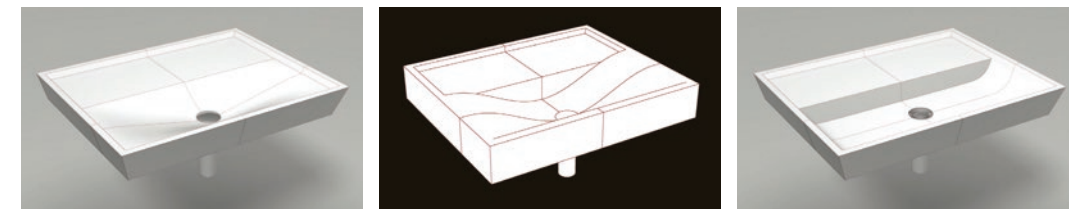
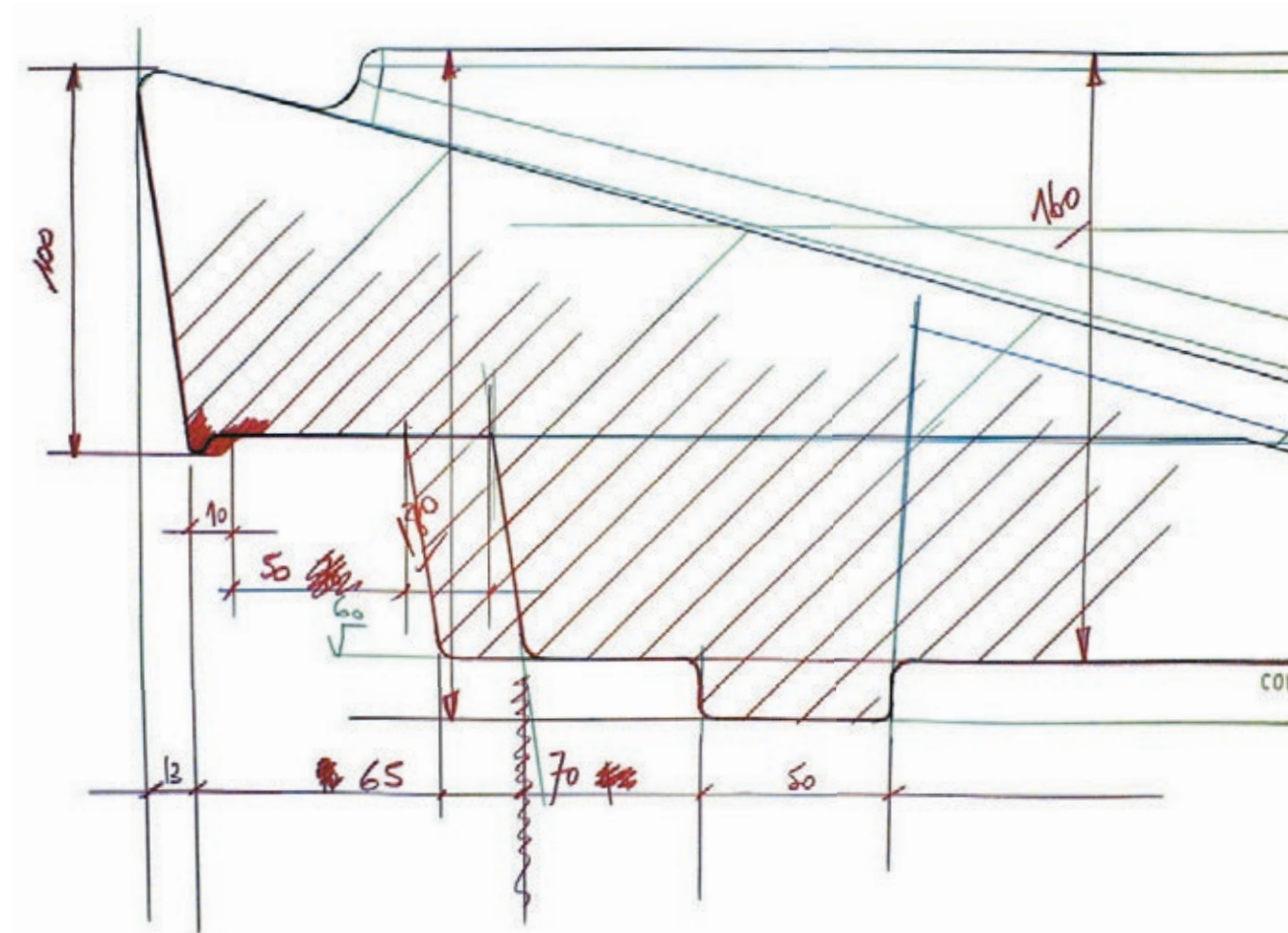
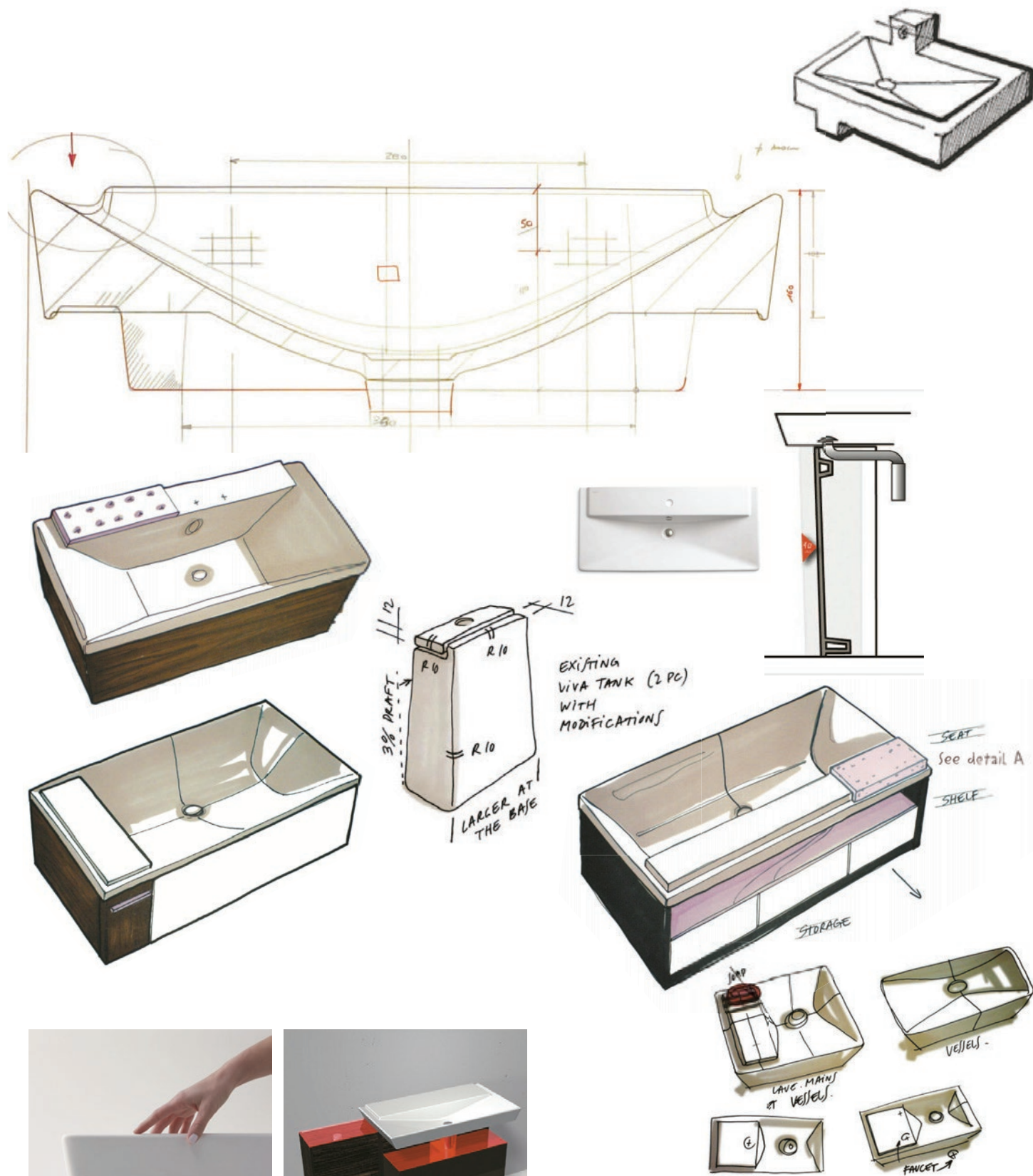



MARGAUX™

Whereas many faucets possess a muted aesthetic in order to complement interiors, Margaux simultaneously demands attention and harmonizes with classically inspired surroundings.

Kohler's American studio created Margaux, when the designers noted the rising popularity of eclectic decorating. Margaux bridges traditionalism and modernism in a similar way, by combining curves and edges with a thoroughly modern stance. In finishing these shapes, the designers made

additional reference to personal objects found in the bathroom, such as quilted linens and perfume bottles. Digital manufacturing ensures that these details have the precise sculpting required to convey their luxurious intent.



For a house to be successful, the objects in it must communicate with one another...

ANDRÉE PUTMAN

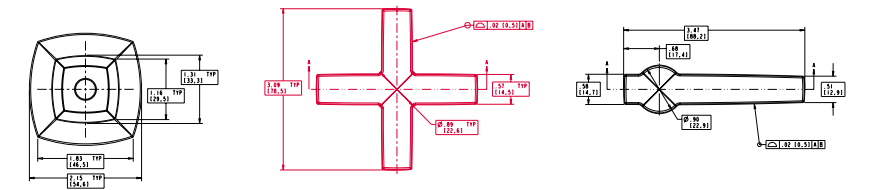
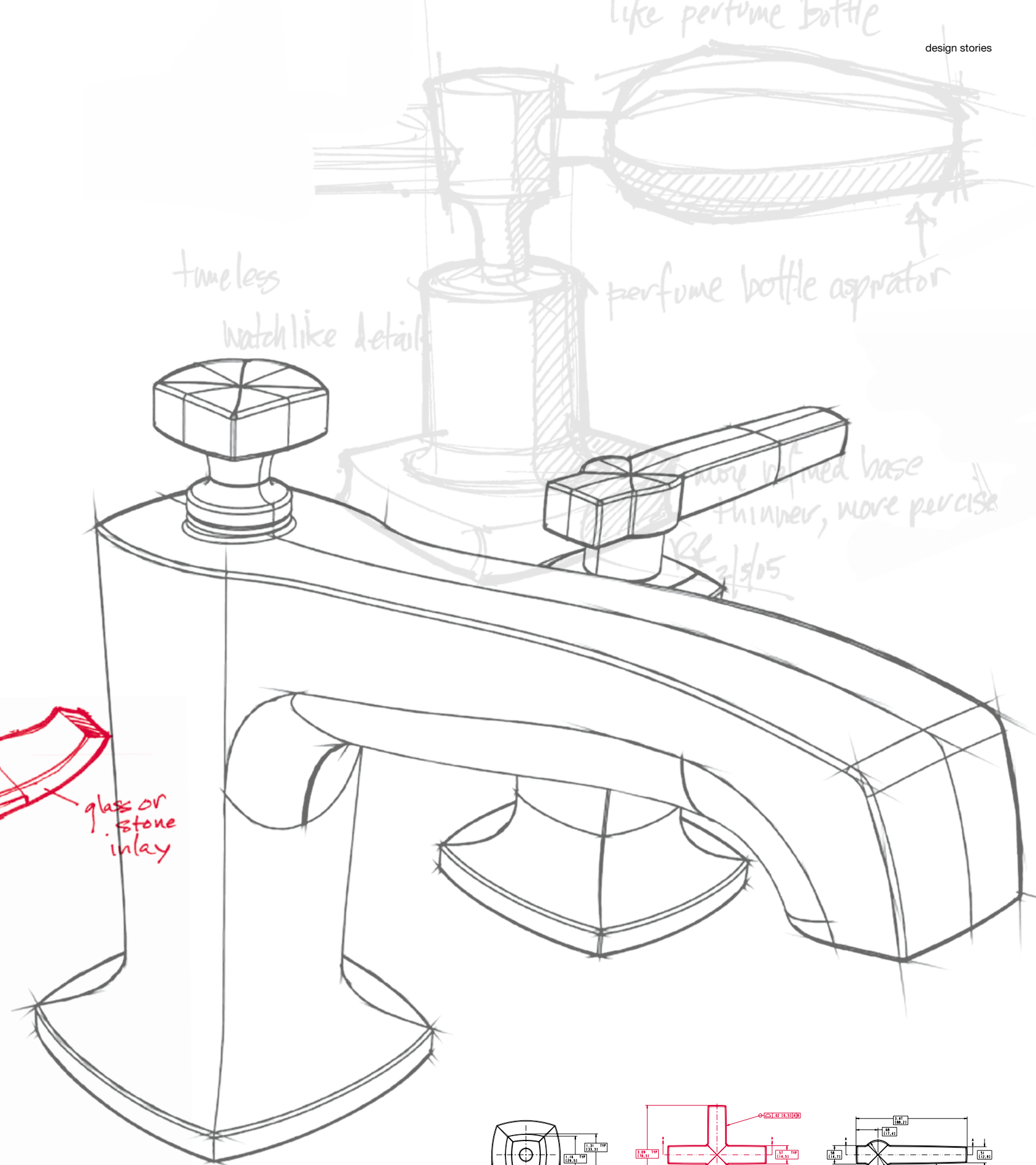
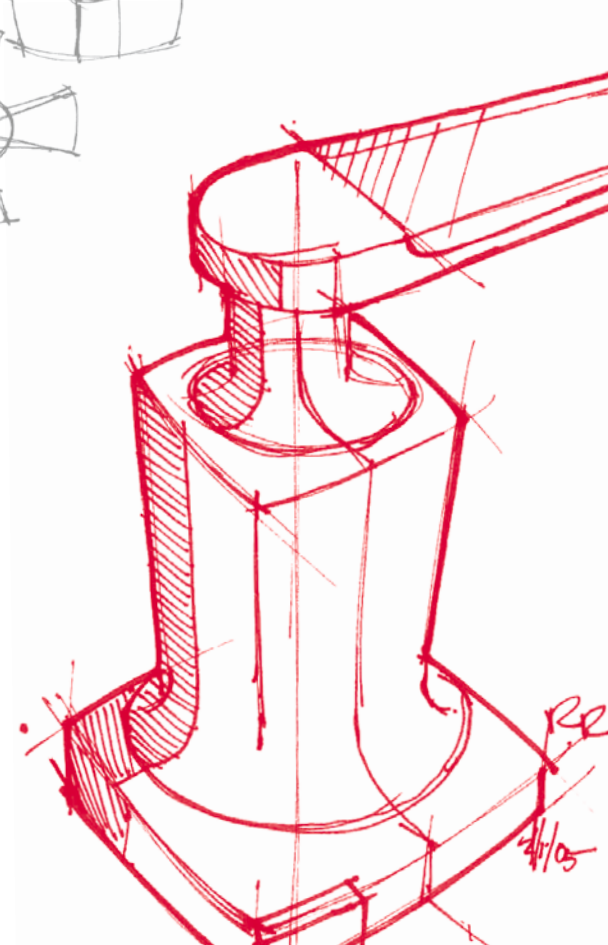
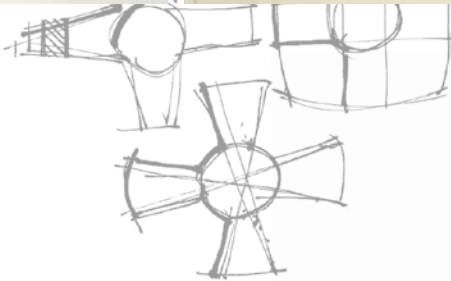

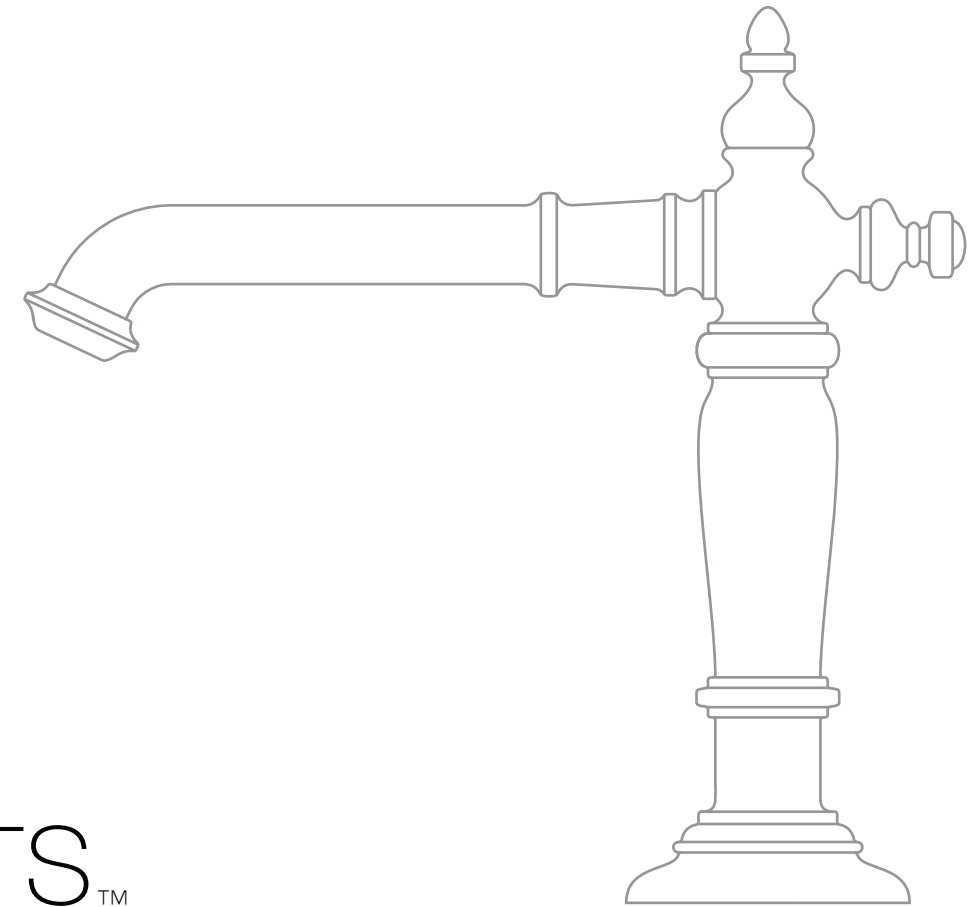

ARTIFACTS™

Wishing to create a collection that allows people to piece together a unique design solution within a system of forms, the Kohler U.S. design studio turned to the past for inspiration.

Artifacts reimagines Edwardian design for today's bathroom spaces. We drew on the overall aesthetic of turn-of-the-century designs reflecting the ingenuity of practical-minded craftsman who made do with the resources at hand.

Artifacts revives this pragmatic approach within the context of

a culture that embraces highly personalized design. We wanted each piece of the collection to be distinct in form and ornamental details, yet to feel part of a whole. Artifacts, with multiple spout and handle options featuring detailed turnings and finials, allows people to compose a space one piece at a time, each piece chosen for its particular character.

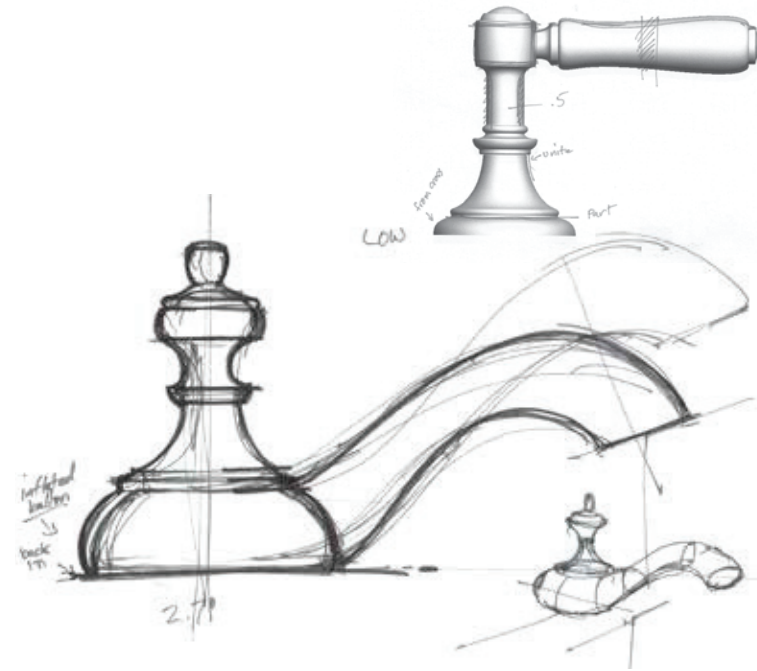
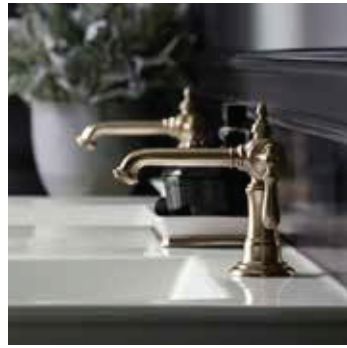

Imagination is the beginning of creation. You imagine what you desire, you will what you imagine and at last you create what you will.

GEORGE BERNARD SHAW

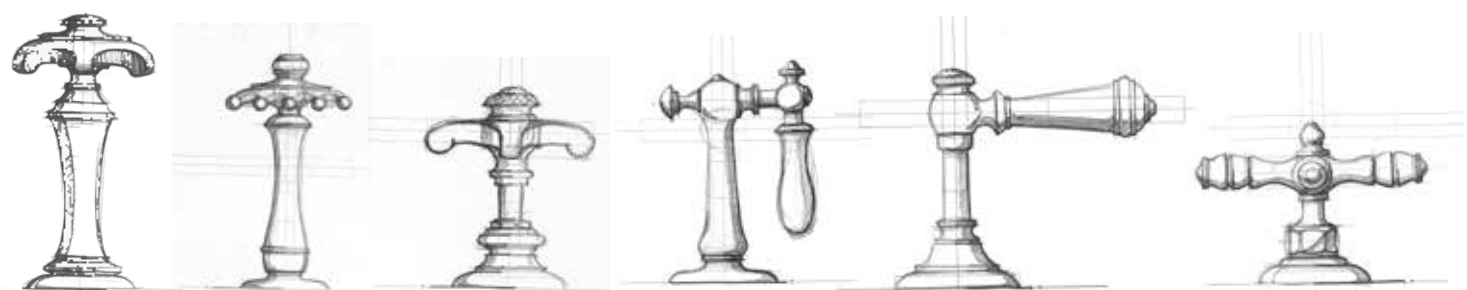
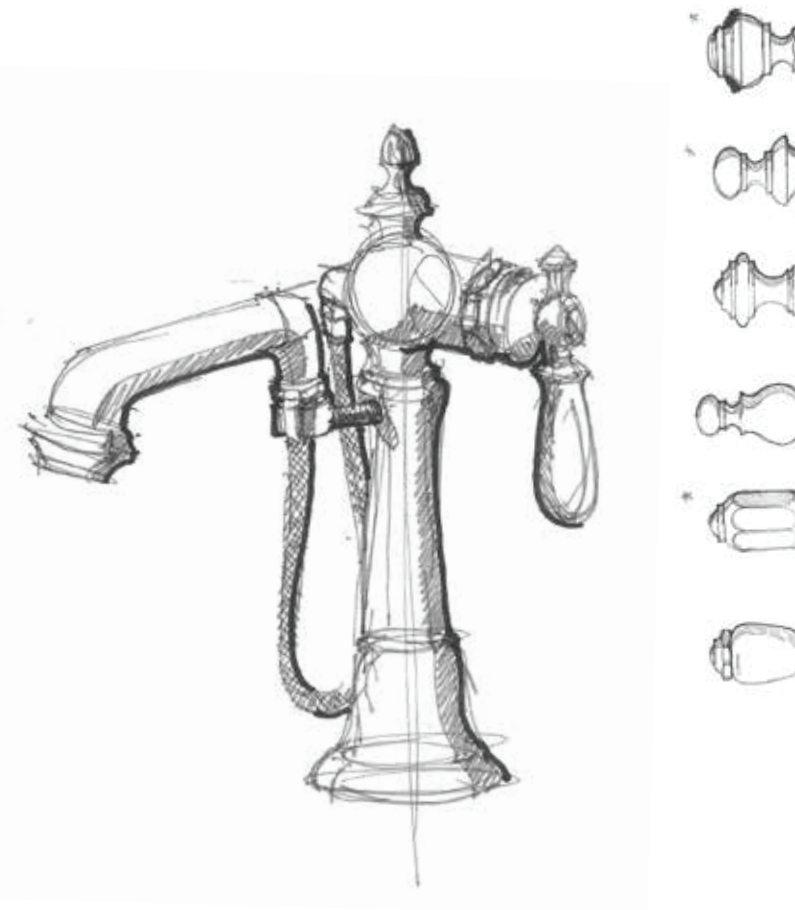

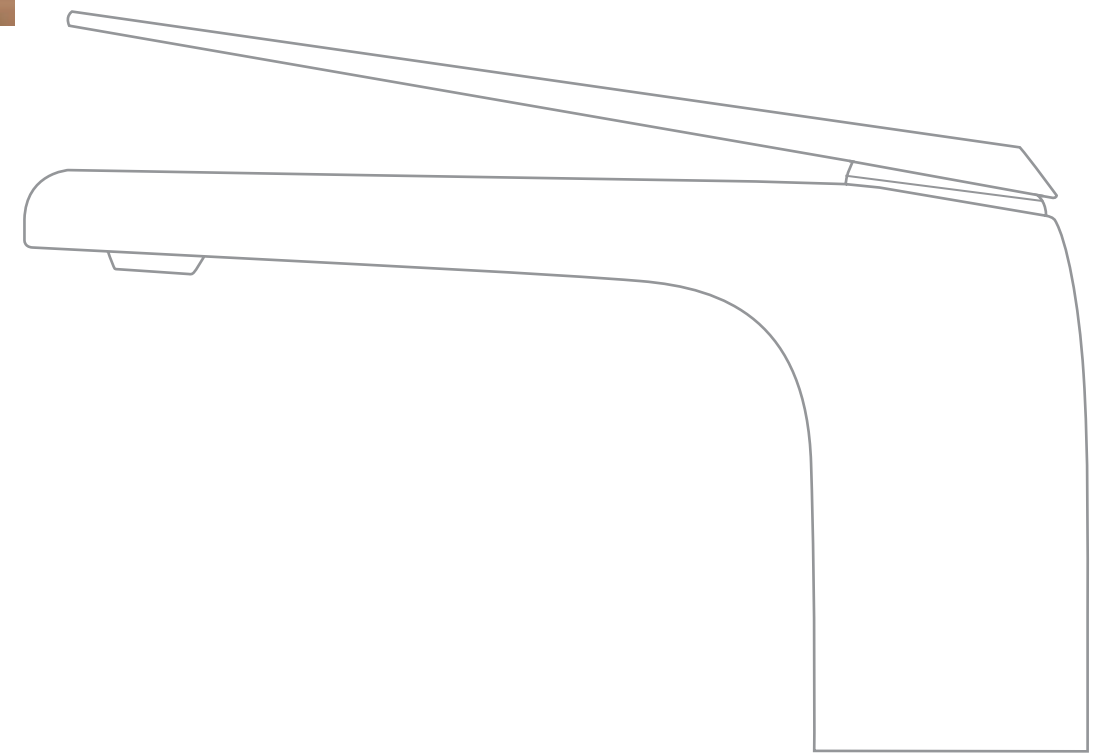

AVID™

Contemporary interior design has an infinite variety of expression. To discover the potential for new and inspiring faucet designs, we continuously converse with designers and consumers worldwide, probing for insight and meaning that we can connect to with new design. This work caused us to debate emotion in modern design and consider how to craft minimalism, to prevent it from becoming impersonal without resorting to known visual characteristics – a non-referential modernity, without a backward glance.

A global design team, using the cultural conversations as a springboard, set about encapsulating contemporary mood in metal, seeking sensitivity and emotional connection without sliding into embellishment or cliché.

Avid's elegant, modern and somewhat feminine form was created by the U.S. team following an extensive collaborative concept period. Fluid metal flows from deck through

spout. As it turns forward, Avid splits, projecting a graceful fingertip-control lever far forward. The lever connection is pushed as far back as possible to maintain a continuous flowing surface through the 90-degree turn.

By pairing painstaking simplicity with visual comfort, versatile Avid creates an inviting emotional response and coordinates with most contemporary bathroom interiors.



Original 25mm



NEW 35mm

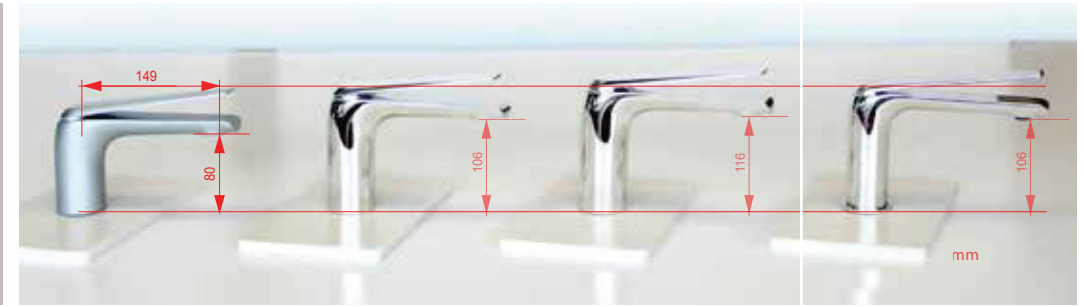
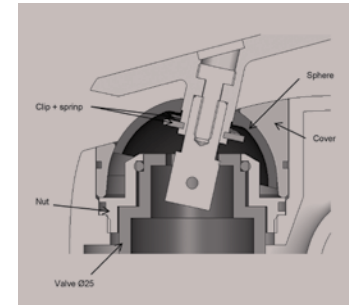

Composed™ and Avid™ mark a new era of global collaboration at Kohler. When research revealed consumers' desires for diverse self-expression and contemporary design within bathroom interiors, Kohler called upon all five of its design studios to create a response. International colleagues supported development, critique and completion of two concepts that emerged from the initial request. Submissions from the U.S. studio eventually won, however, the interaction of designers, immersed in their local cultures, of diverse cultural backgrounds and experiences, catalyzed the creation of a tantalizing spectrum of designs. Creativity is endless – with an open mind there are so many ways to create delightful meaning!

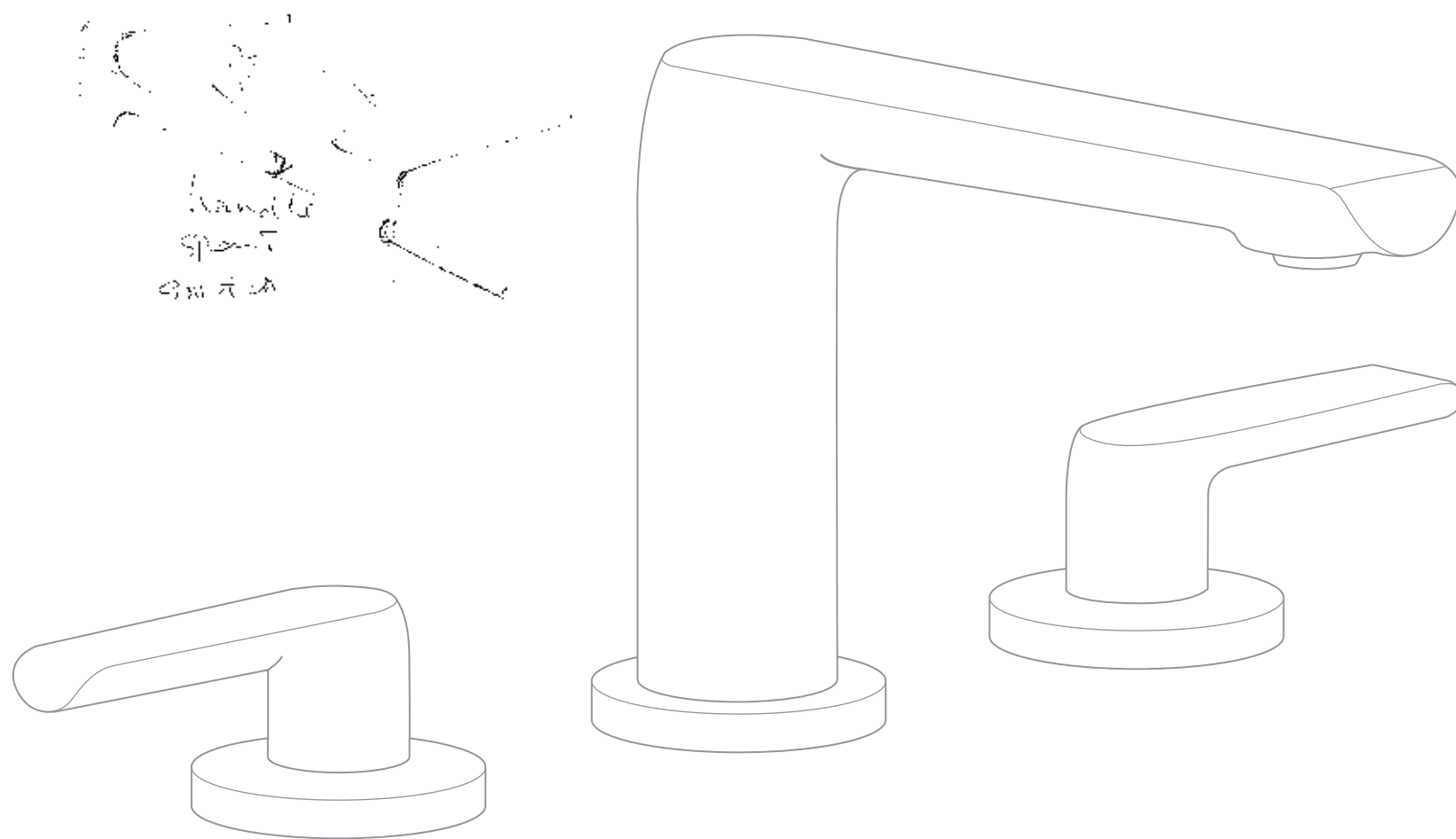

Design dissolving
into behavior.
SUSAN SONTAG



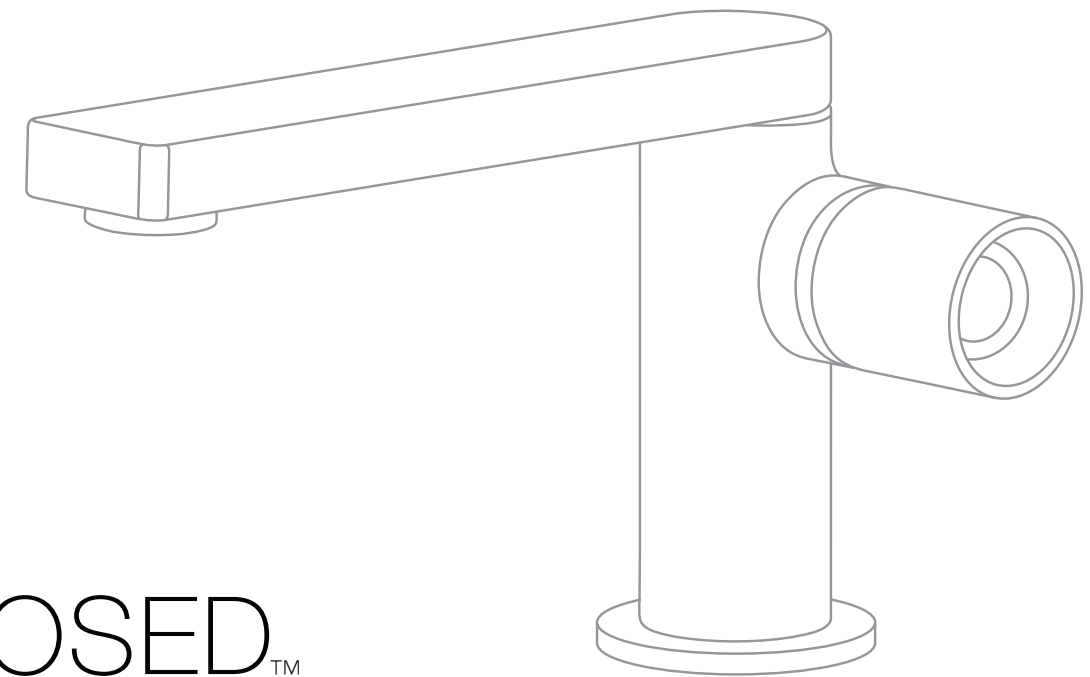

COMPOSED™

Diversity within interior design delights and inspires designers at Kohler. Communications and social media streams now fuel experimentation, the leading edge dancing forward constantly. Against this fluid backdrop, creating new product demands clarity of purpose and a refusal to compromise.

Resonant within our observations was the repeated role of the best of the best, those seemingly timeless pieces that find purpose in many interiors. They are frequently simple, always highly resolved and truthful to their intent.

This mindset led us to explore the meaning of a minimalist masterpiece in modern times with the intent that when honestly formed, it could play a wide variety of roles within the flux of interior expression in modern bathroom architecture.

Inspiration for Composed finally came from Rowena Reed Kostellow, a professor at Brooklyn's famed Pratt Institute between 1939 and 1988. Kostellow showed generations of artists and designers how to transform precisely defined basic shapes into visual poems that elicit an emotional response. The single-handle faucet led our exploration. Often the most difficult piece to design, with our self-imposed goal it would set the standard for the Composed range. Its elements were repeatedly refined

and reduced, seeking to achieve poise and purpose from the most compact circular and rectilinear forms. A side-mounted control was introduced to strictly maintain the visual balance, whilst providing sensitive fingertip adjustment. Joystick and widespread models carry more conventional handles but have the same disciplined attention to detail.

Composed is obsessively so. The intent is to delight in detail whatever its role within the interior.

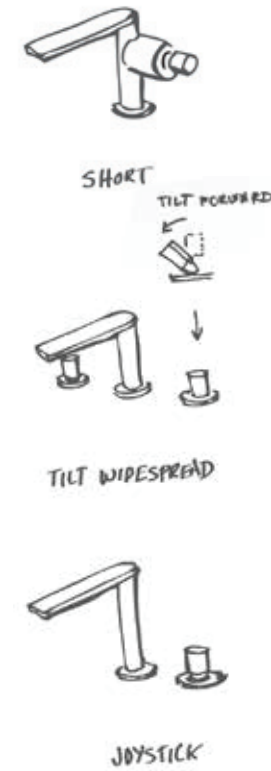
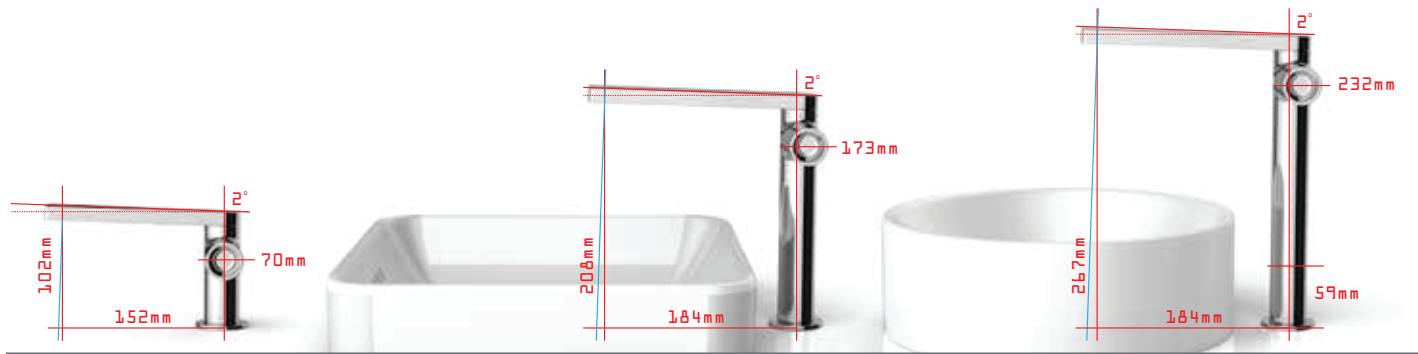
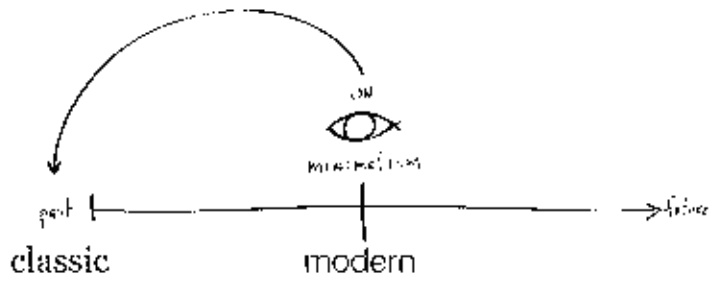

Design exploration only, not part of final Composed collection.

art is the elimination of the unnecessary.
PABLO PICASSO

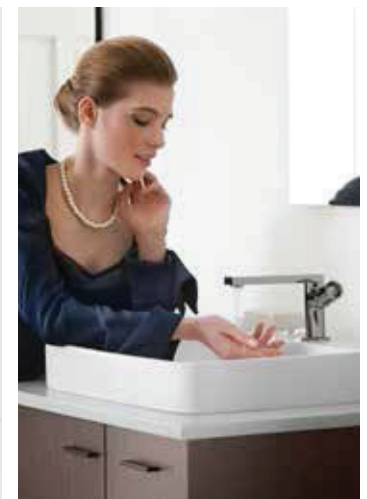
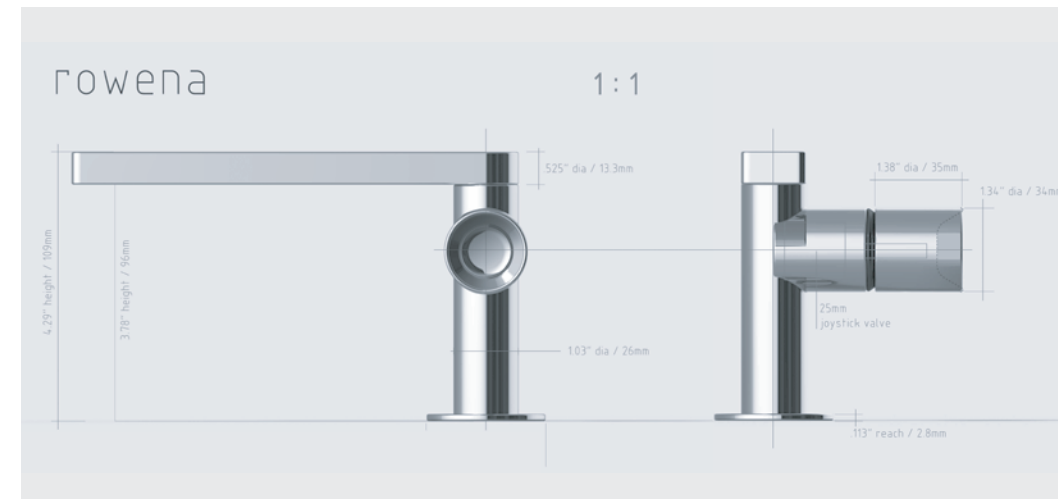
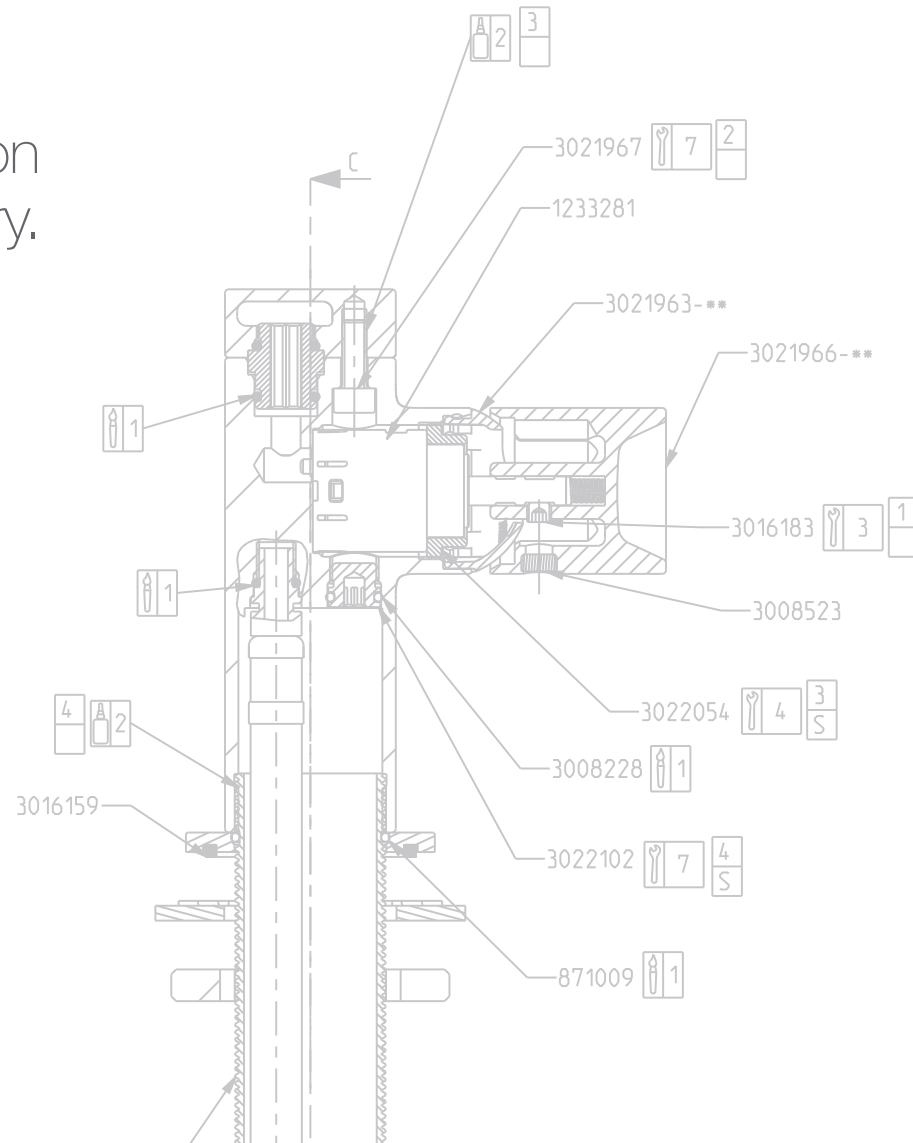

single-handle faucets

The handle designs favor a minimalist aesthetic for a timeless beauty. The pure handle offers pure simplicity with a touch of whimsy and surprise, while the joystick provides elegance for a distinctive visual statement.



pure handle

lever handle

joystick

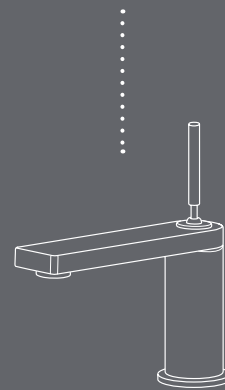
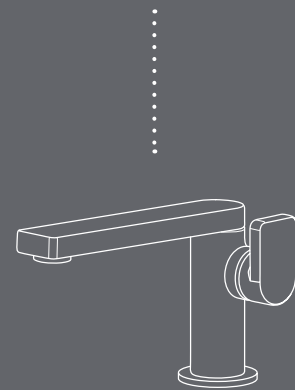
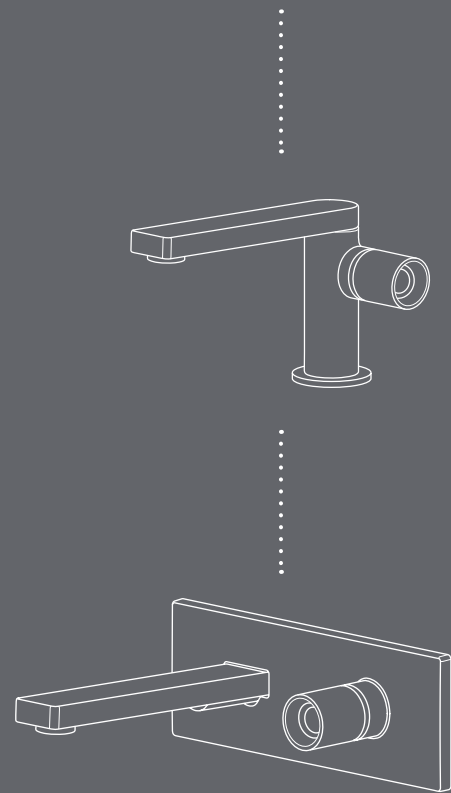

widespread faucets

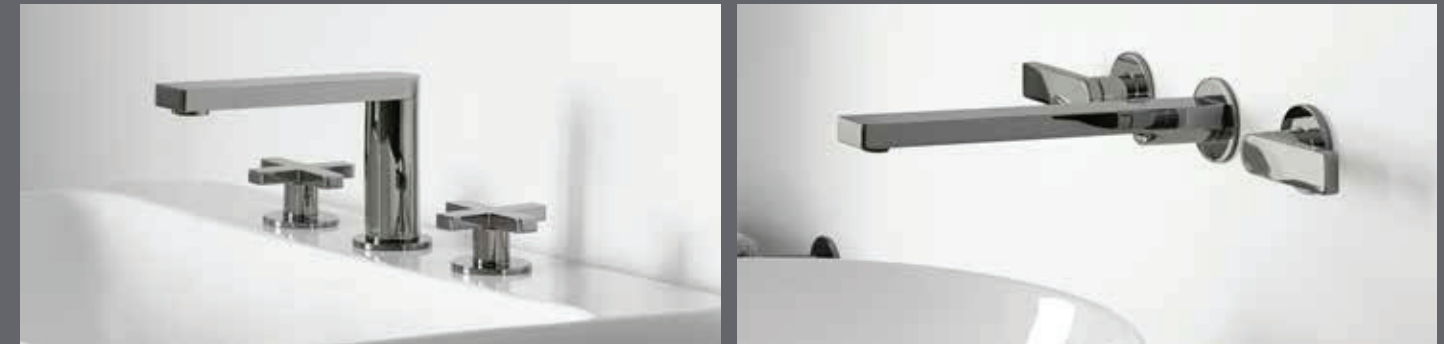

cross handles

lever handles

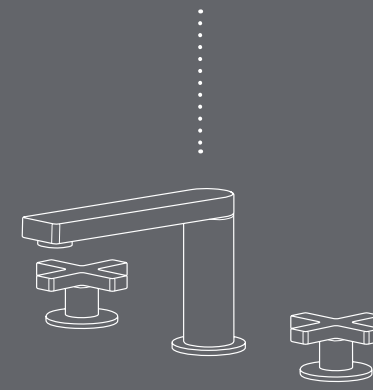

deck-mount

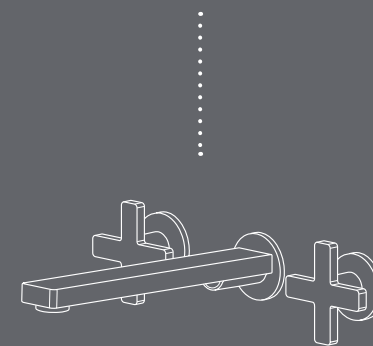
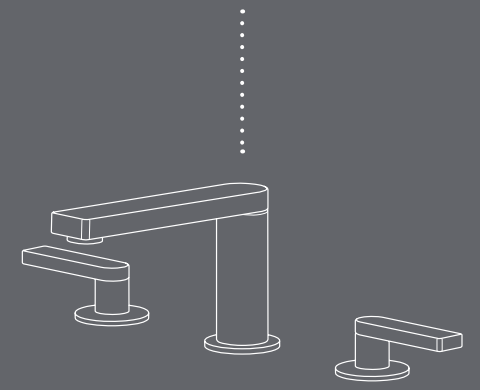

wall-mount

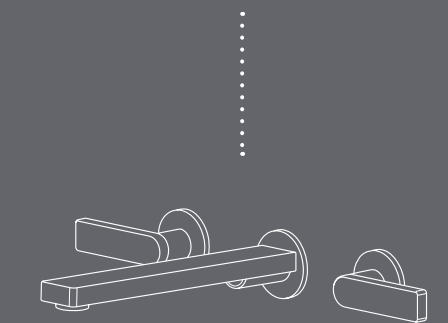

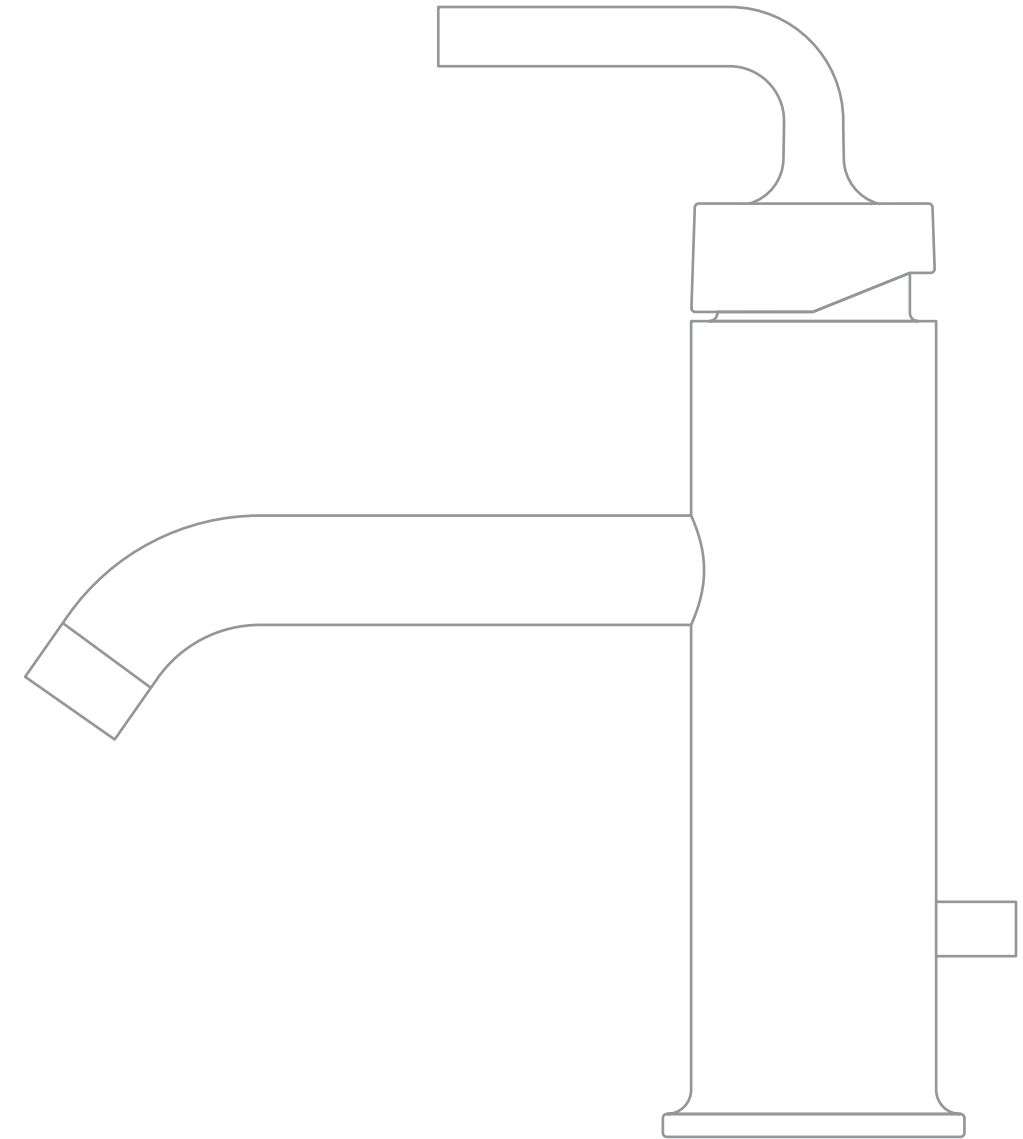

PURIST™

In our conversations with designers and consumers about the bathrooms they were wanting to create, personalized minimalism was a frequent topic. The calming allure of perfect proportion, order and refined detail has an enduring and broad appeal – a counterpoint to a 24/7 lifestyle. For some, this disciplined architecture is all that's needed, but for many it forms a background against which individuality can then be expressed through objects, art or carefully chosen design. This is how we approached the design of Purist; we wanted to achieve simplicity with soul to provide a choice for a discerning eye.

The U.S. design team led the design and reduced the product to its basic elements as a starting point. Delving into the industrial origins of water supply, they were inspired by the cast, forged and wrought components where form clearly followed function.

A simple hand pump led to the unique body, handle and spout architecture which defines the Purist bathroom sink faucet and is the essence of the range. We stripped this iconic form back, making adjustments for

the bathroom application but staying true to the functional intent. In our research, we also found the source of the faucet's subtle character. To anchor the product, we designed a turned escutcheon inspired by industrial-revolution-era mouldings and industrial couplings. Handles start and finish with precise external and internal radii to give a quietly decorative strength.

Purist is minimalism with a twist. Contemporary, versatile and confidently original.



In history,
a great volume
is unrolled for
our instruction...
EDMUND BURKE

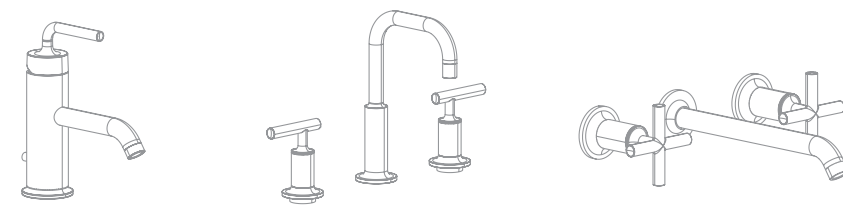

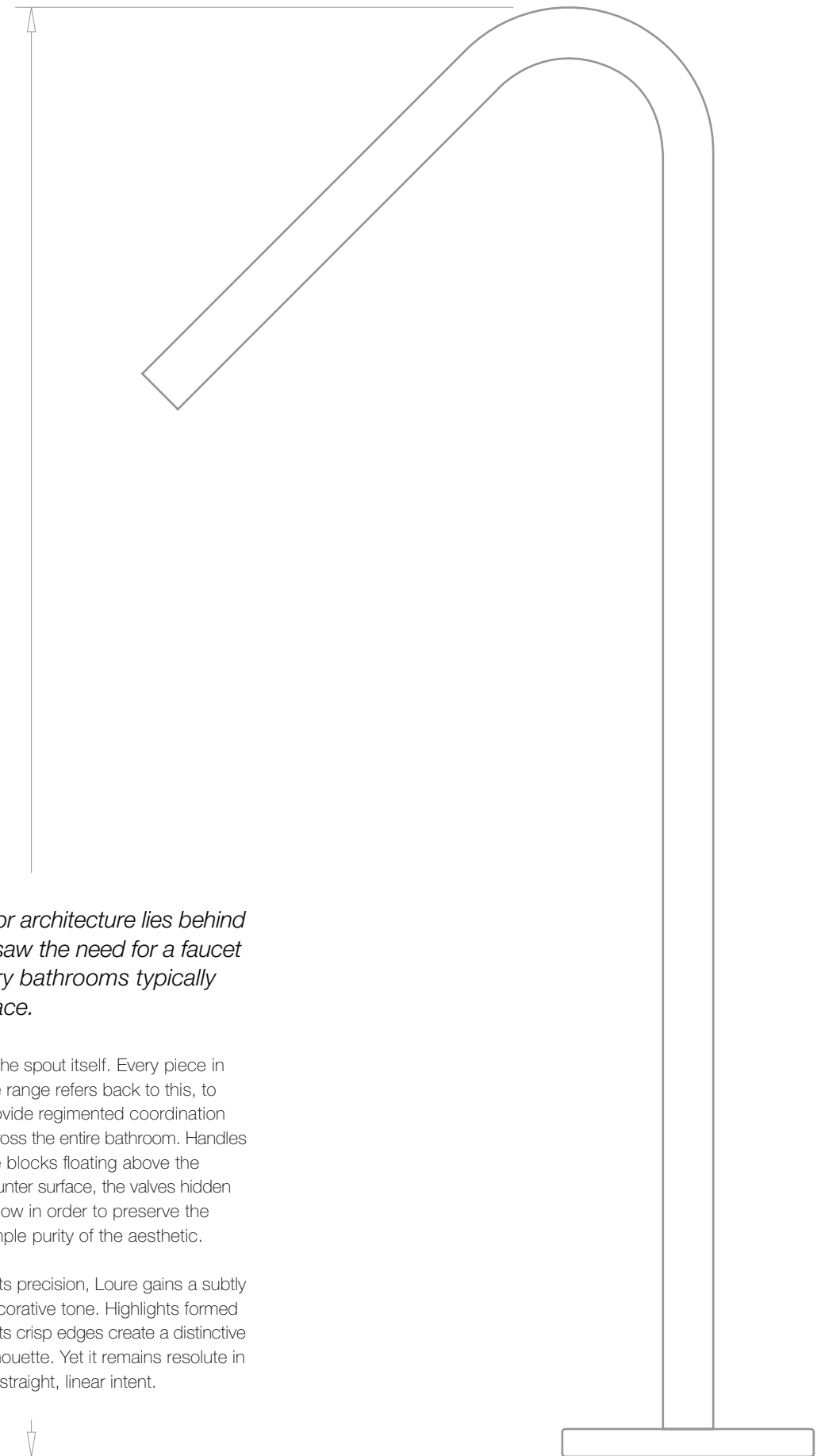

LOURE™

Geometric composition in interior architecture lies behind the design intent of Loure. We saw the need for a faucet that was able to enhance luxury bathrooms typically described by linearity and surface.

This idea of surface came to define the product. We saw the potential to build upon some of the principles we had established within Stillness™ and its approach to reduction of complexity in order to achieve purity. By folding a sheet of water to take it from source to destination, we established our language. Its form is linear, planar and almost two-dimensional. Water clad in metal, seemingly laser-cut and formed from a single sheet. Its width is defined by the intended function; the water stream it provides is an extension

of the spout itself. Every piece in the range refers back to this, to provide regimented coordination across the entire bathroom. Handles are blocks floating above the counter surface, the valves hidden below in order to preserve the simple purity of the aesthetic.

In its precision, Loure gains a subtly decorative tone. Highlights formed at its crisp edges create a distinctive silhouette. Yet it remains resolute in its straight, linear intent.

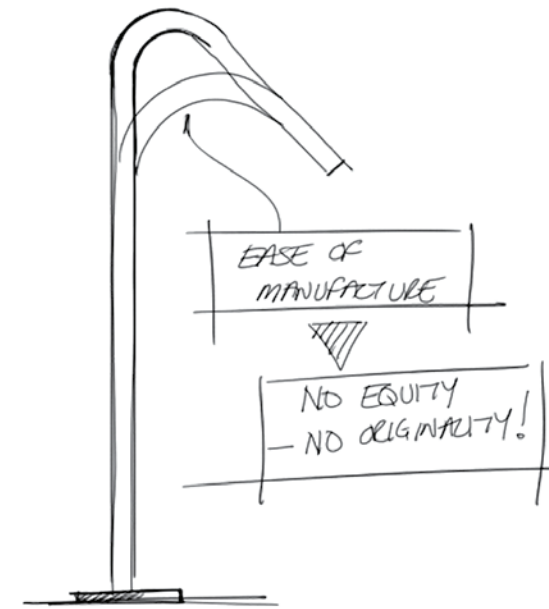

The real voyage of discovery consists not in seeking new landscapes, but in having new eyes.

MARCEL PROUST

Stegastein viewing platform, designed by Todd Saunders/Saunders & Wilhelmsen for Nasjonale Turistveger.

Stegastein viewpoint along the Aurlandsfjellet National Tourist Route, Norway
 Photographer: Vegar Moen
 Architect: Todd Saunders/Saunders & Wilhelmsen

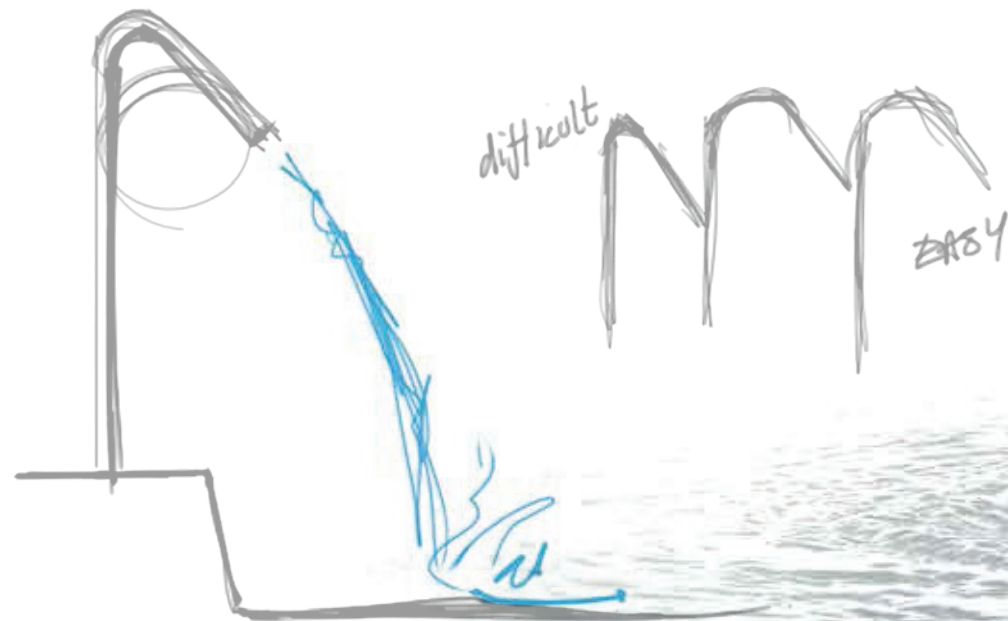

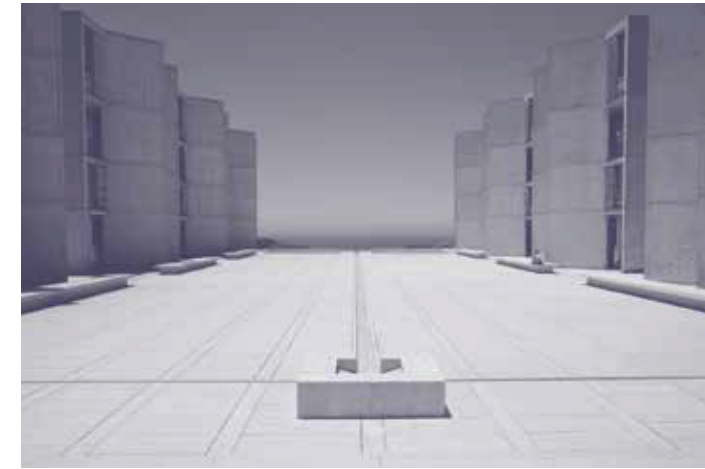

STANCE™

Bathroom design is adapting to the pampering and grooming rituals that are part of modern lifestyle, demanding enlarged areas for us to lay out our select beauty and care products, with storage to conceal them when not in use. Thus cubes and surfaces, geometrically defined, frequently describe a modern bathroom.

This observation led us to the intention to create a primarily cubic faucet range that could stand confidently within the bathroom environment. As our concept exploration began, our thoughts revolved around the presentation of a simple plain surface to the user that would completely contain both control and water delivery. Any other form would recede to a supporting role.

Hence, from the user's perspective, Stance is just this: a presentation of water at a convenient height set on a strong upright pillar, reduced and set back so as not to interrupt. Joystick lever control allows interaction to be totally bounded by the top surface, while close inspection reveals an underside seemingly formed by the water flow that it contains and delivers. The

duality of mass and a cantilevered slim surface pushed boundaries in body-casting processes, requiring innovative cooling systems and led to final design detail only made possible by intimate interplay between designer and manufacturer.

Stance is surface made solid.

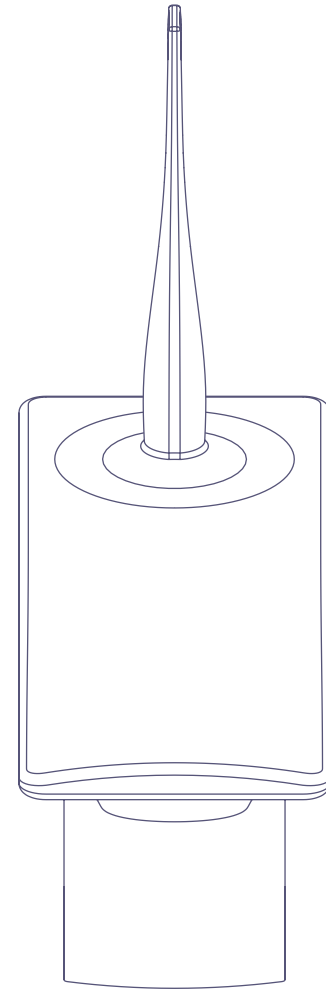
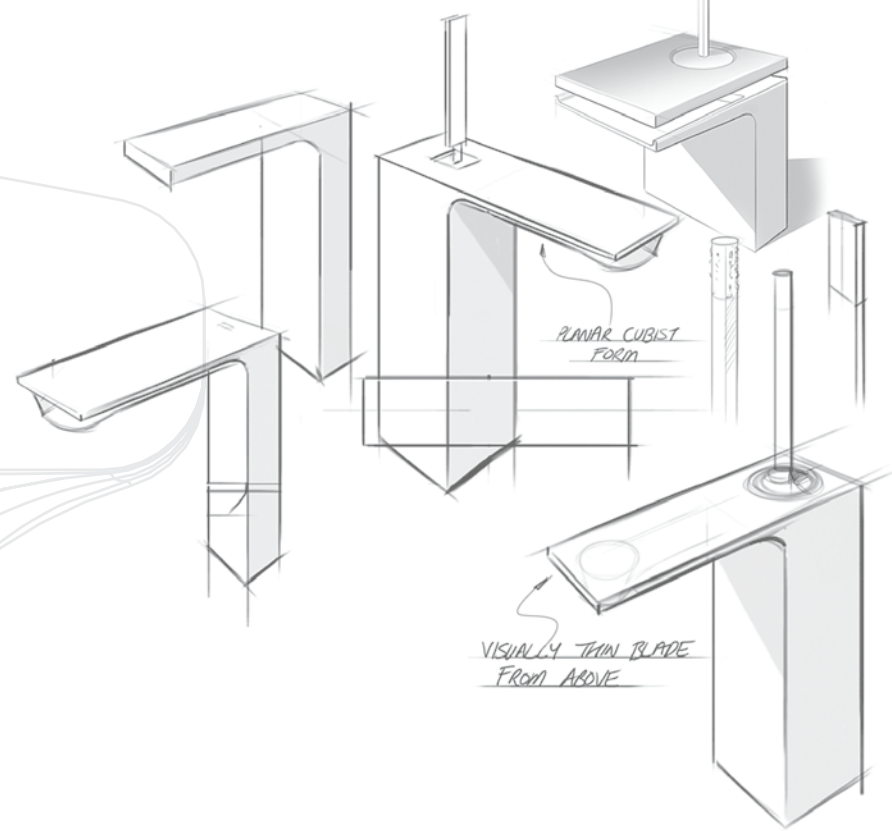

Simultaneous contrast is not just a curious optical phenomenon—it is the very heart of painting.
JOSEF ALBERS

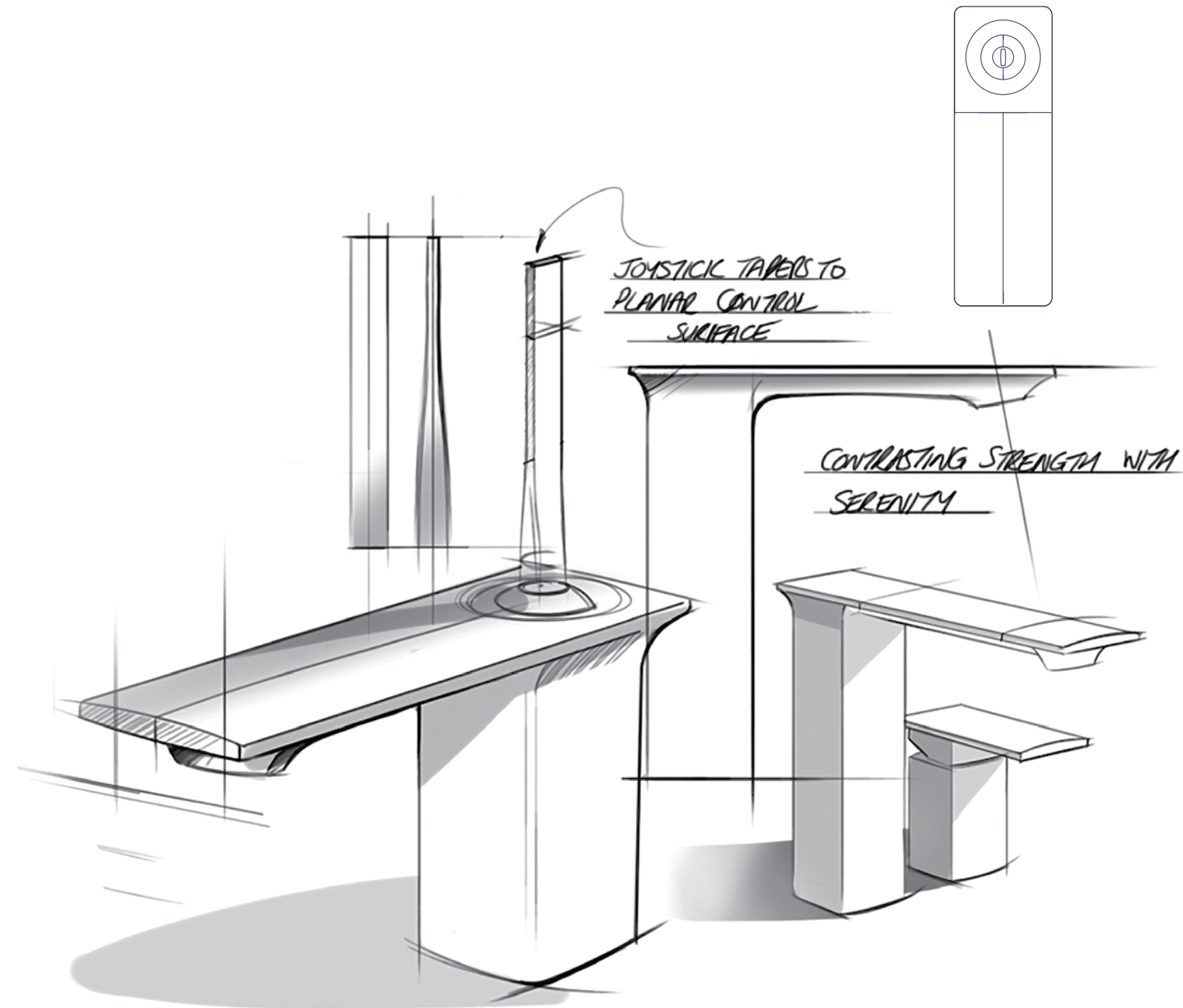

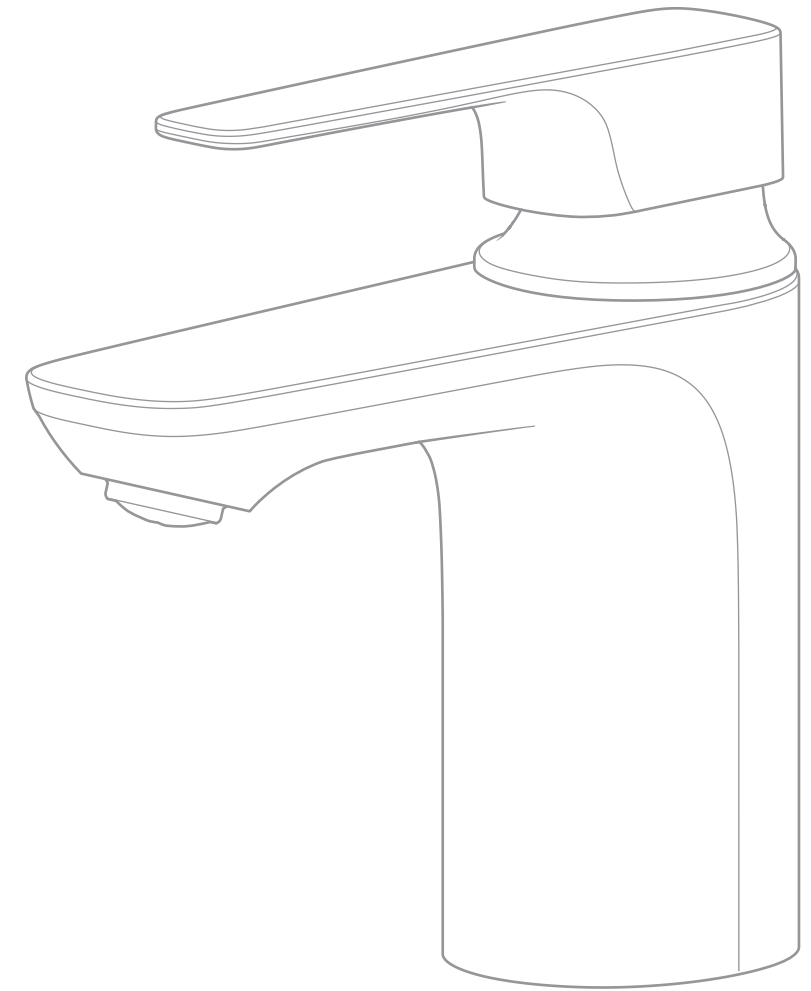

ALEO™

The design of Aleo and Aleo+ resulted from our research into the evolving and complex nature of modern urban lifestyle. There is a conflict in priorities emerging between work and home and efforts to find a new balance. The role of the bathroom is evolving constantly as a result. No longer is it just a place to bathe, but an extension of living space, with a multi-mode, multi-person role demanding the highest standards of design, hygiene, performance and intuitive functionality.

The Paris studio led the design and began by exploring compact, democratic forms that could simultaneously convey robust quality and precision within a friendly intuitive form. The concepts resulting were exacting compositions of masculine and feminine meanings seeking to create a relevant and original solution with a modesty and

balance that solves and does not create problems.

Its flat-topped handle and spout with a clean, symmetrical edge announces precision construction; the sinuous underside of the spout and the blending of body to sink deck is softened and approachable. All are seamlessly integrated with

an engineered-polymer core that provides unparalleled hygiene and ease of maintenance.

Aleo's design reflects modern efficiency, invigorated by very few gestures, while enhancing the ease with which users can handle and clean the faucet.

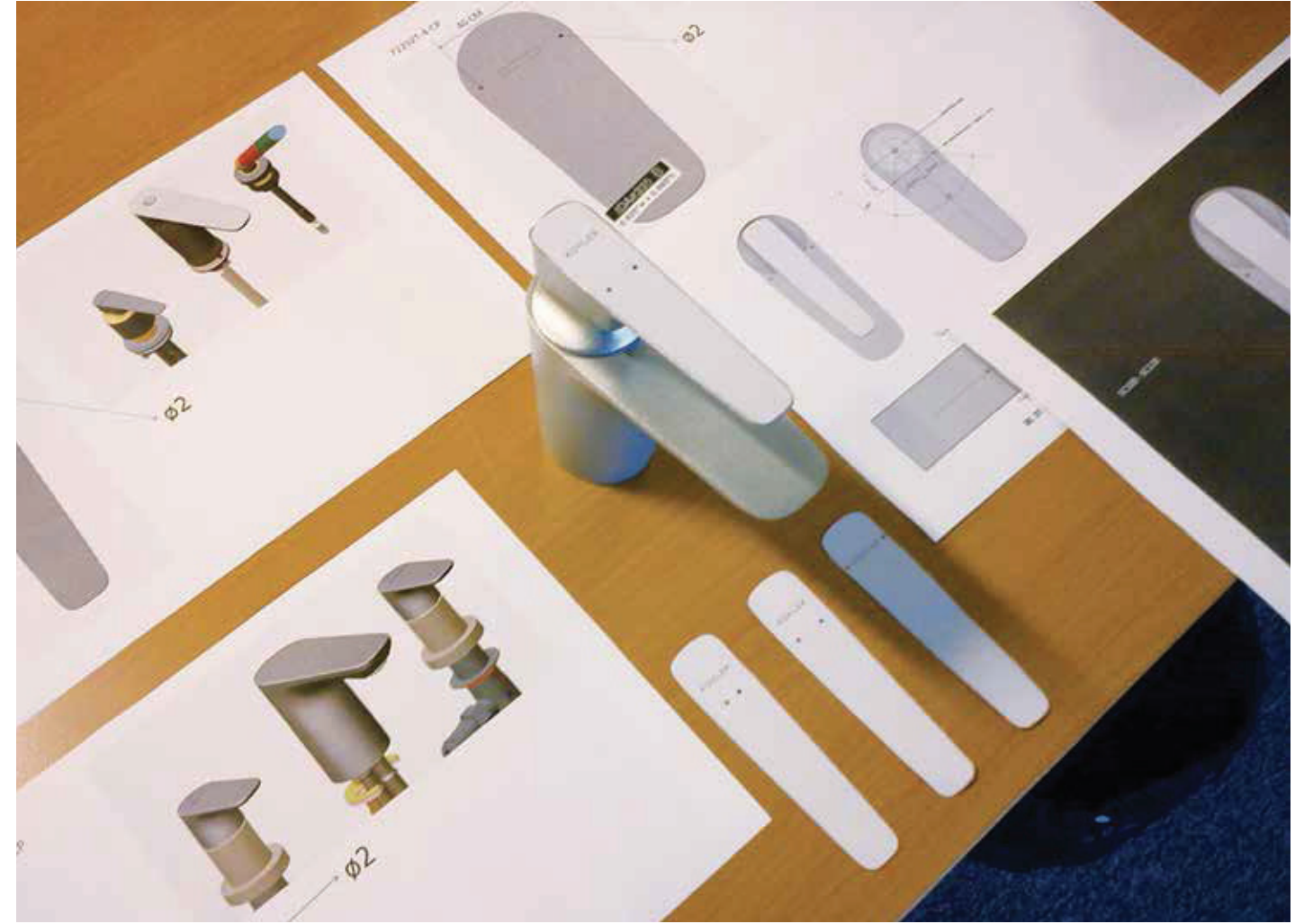
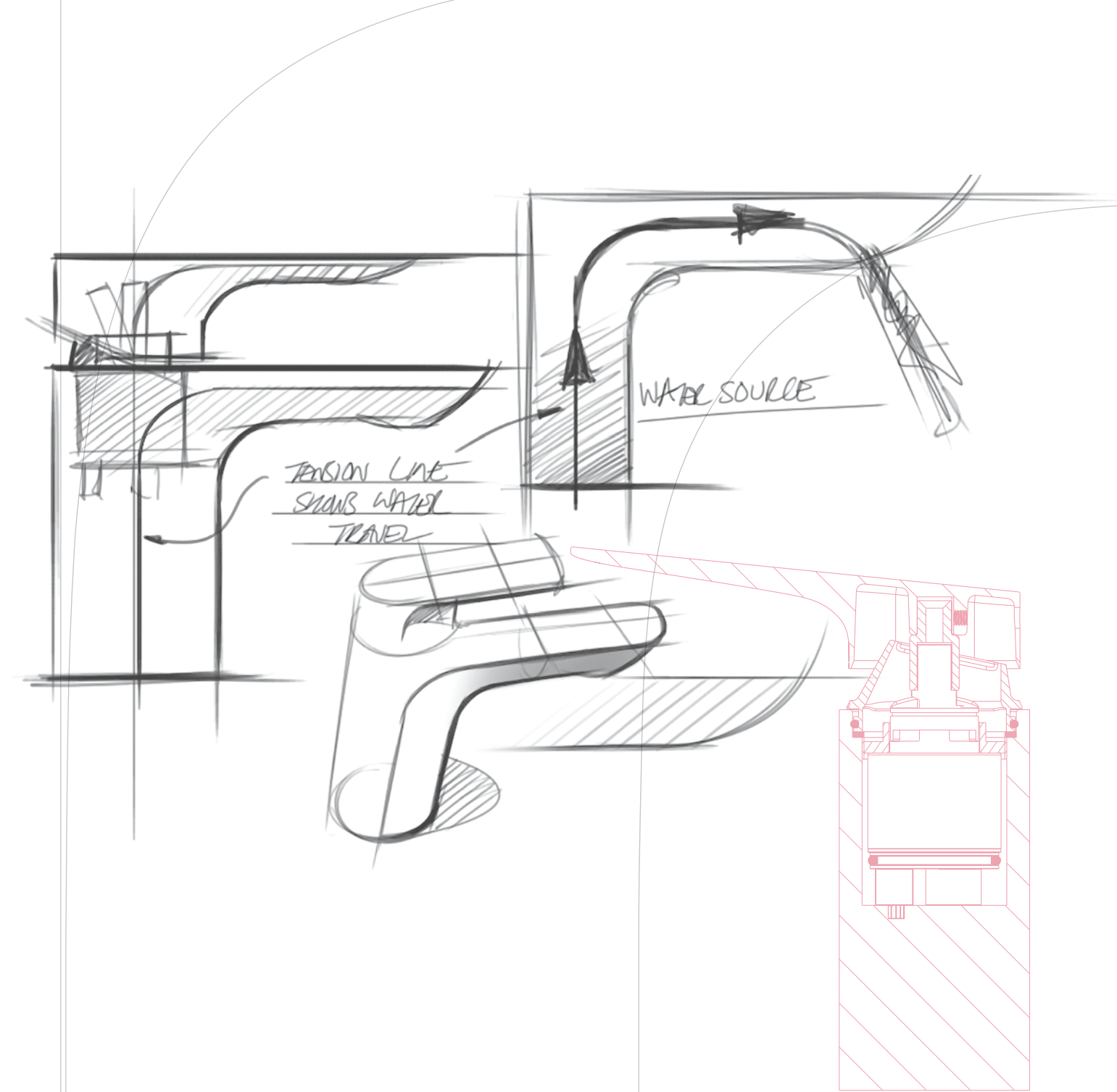
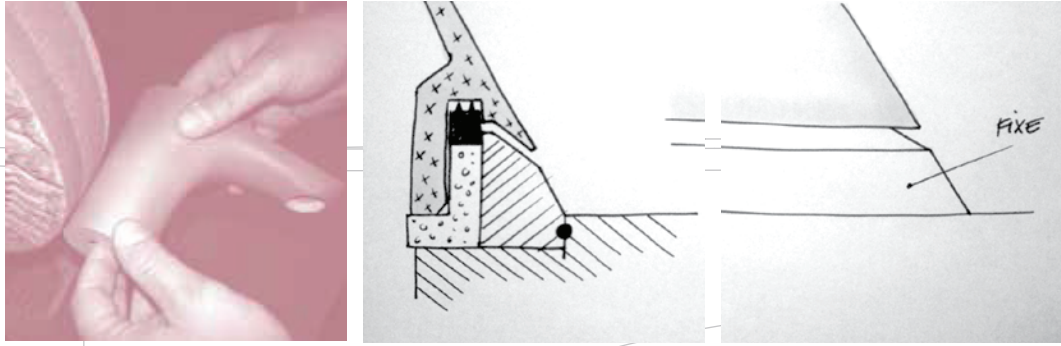

The chief function of the city is to convert power into form, energy into culture...

LEWIS MUMFORD

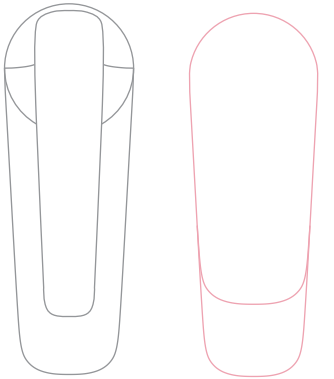

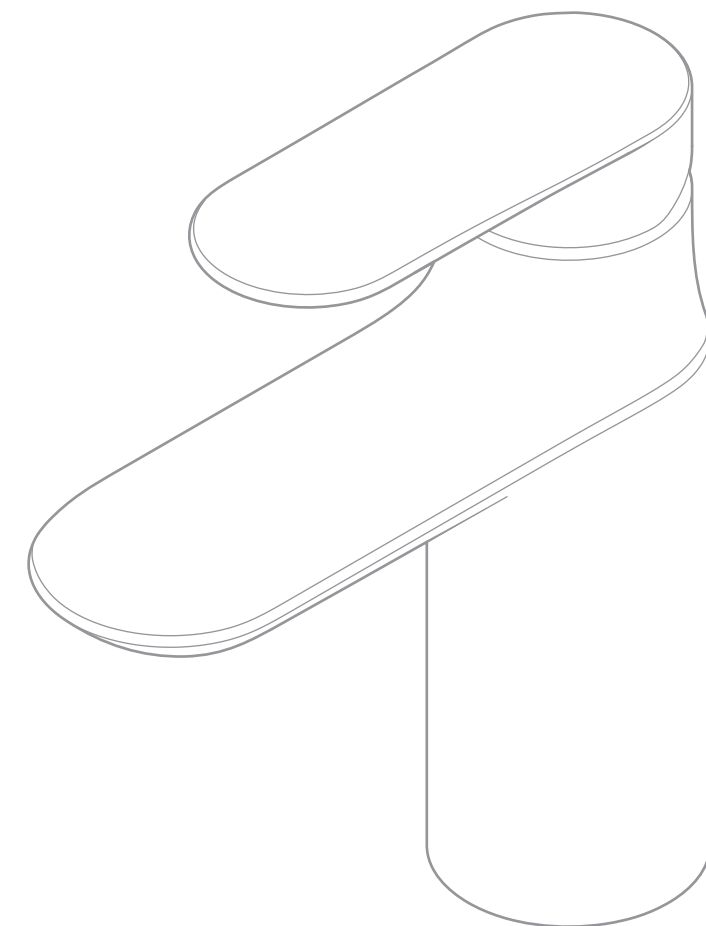

KUMIN™

Kumin represents a company-wide belief that all people deserve great design and embodies modern design at an entry-level price in the KOHLER® family of faucets.

Created by Kohler's London studio, Kumin is based on conversations with consumers worldwide that identified potential for relevant originality in a relatable kind of minimalism. In response, Kumin's designer sought to find a balance between a tall, upright stance with a perpendicular spout (embodying functional needs) and a versatile form that is at once modern and warm. Once a conceptual design language had been established that could achieve this, every part of the process was considered in order to enable the creation of a

product with market-leading design and quality at the entry level. Innovation in process was identified that allowed seamless body and spout forms to be cast with great precision, giving the designers clarity and an opportunity to explore.

Thus, Kumin was able to be created with pure geometry – its lozenge-shaped perimeter precisely defining its waist. From this, the body, spout and handle are formed in a tense domed form that implies its purpose: to deliver pressurized water to hand. The intersection between handle

and body is elevated above spout level to integrate these usually disparate forms. An additional benefit to this is ease of cleaning at what is usually a difficult junction.

Simultaneously restrained and personable, Kumin is at once intuitive, memorable and versatile.

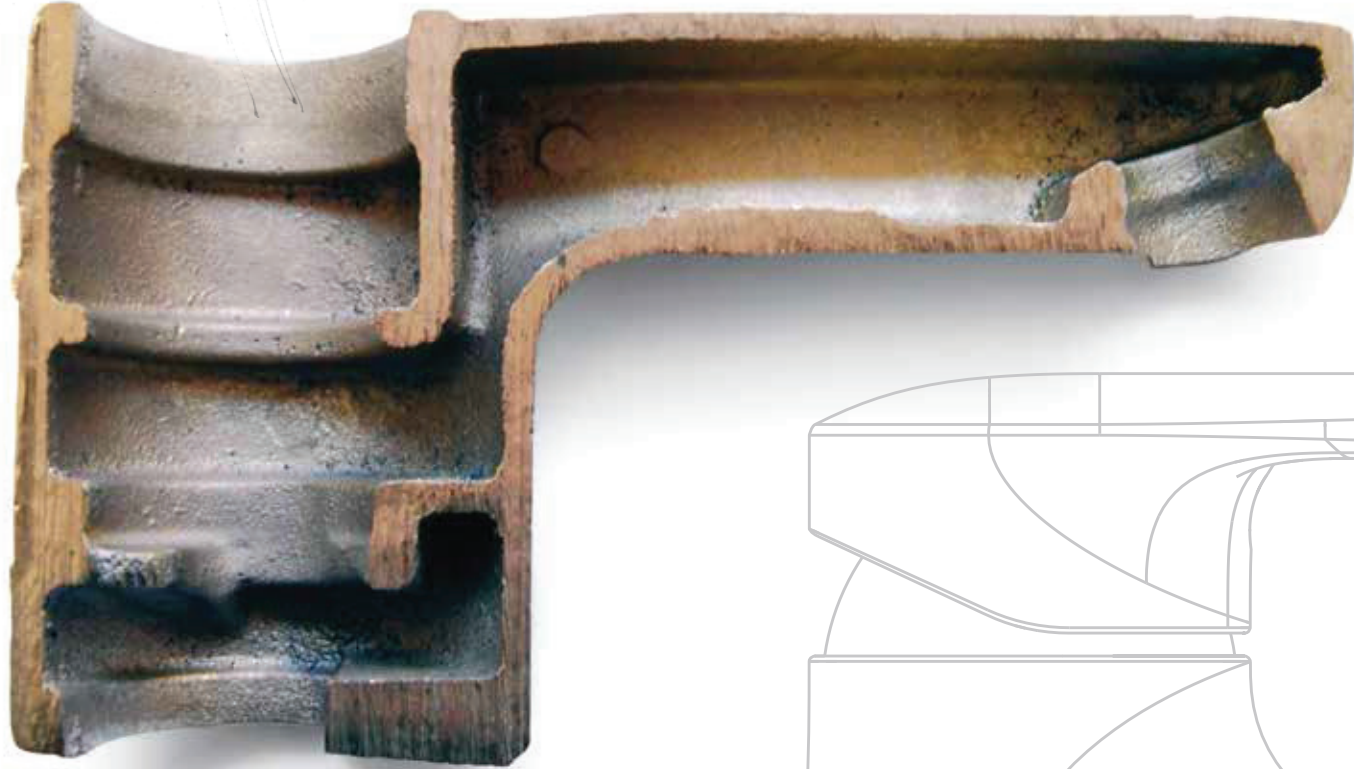
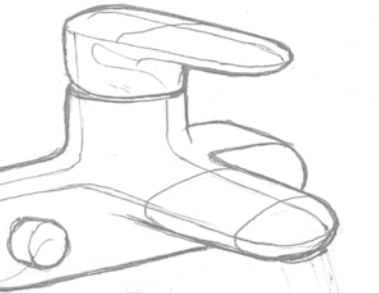
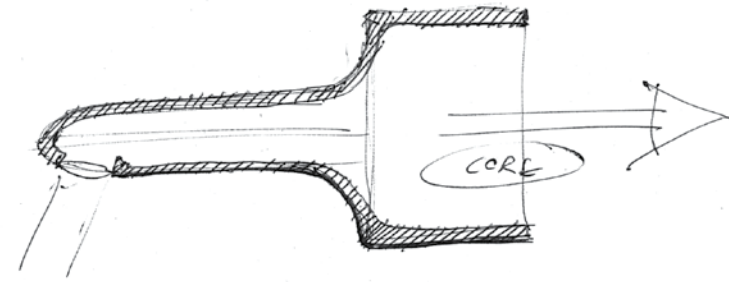

The only ideals allowed
are healthy ones — those
everyone may aspire to...

SUSAN SONTAG

Some of the greatest innovators in history are borrowers, applying existing technology to another market in an unexpected, groundbreaking way. After observing an assembly line at a meat-packing plant, Henry Ford imported the method to car manufacturing. Nature may also be a source of inspiration. Consider George de Mestral, who created Velcro by replicating the attachment formed by burrs hooking into his clothing.

Kumin came to life in a similar way. By casting the faucet's whole shape in one step, Kohler could unlock significant cost savings. Yet the design team also needed that process to yield a precise exterior and avoid costly machining of the surface. Study across industries turned up an intriguing opportunity proven in sports equipment and engine manufacture. Kumin utilizes a hybrid single-casting process, in which precise steel tools mold the exterior while lost cores shape the volume inside the faucet.

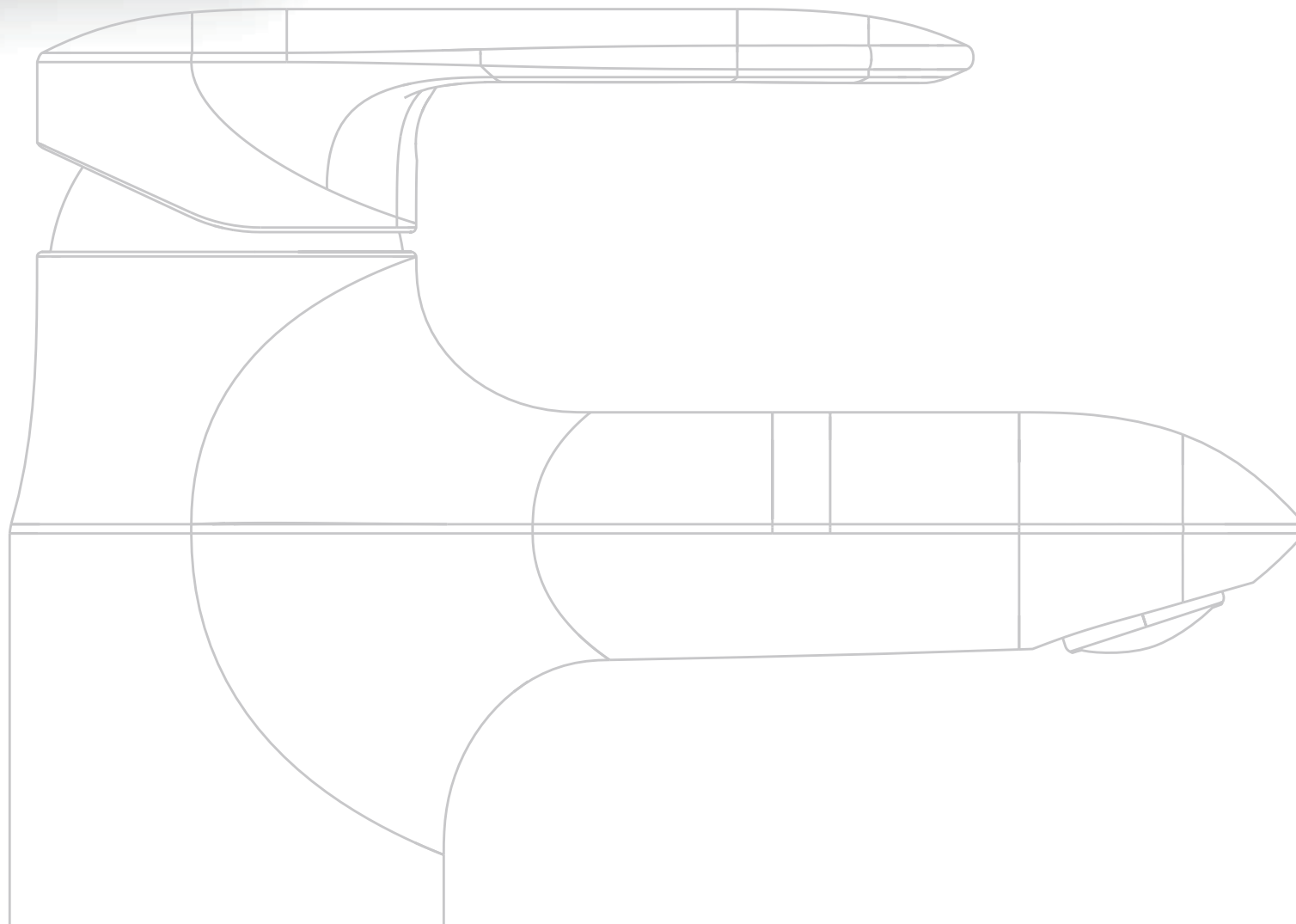

KOHLER DESIGN STUDIOS

KOHLER,
USA

LONDON,
ENGLAND

PARIS,
FRANCE

NEW DELHI,
INDIA

SHANGHAI,
CHINA

KOHLER®